

\* SEE DRIVEWAY DETAILS FOR WIDTH AND RADIUS

ORIGINAL CURB AND GUTTER TO BE REMOVED. ASPHALT TO BE PATCHED AS REQUIRED.

**PLAN**

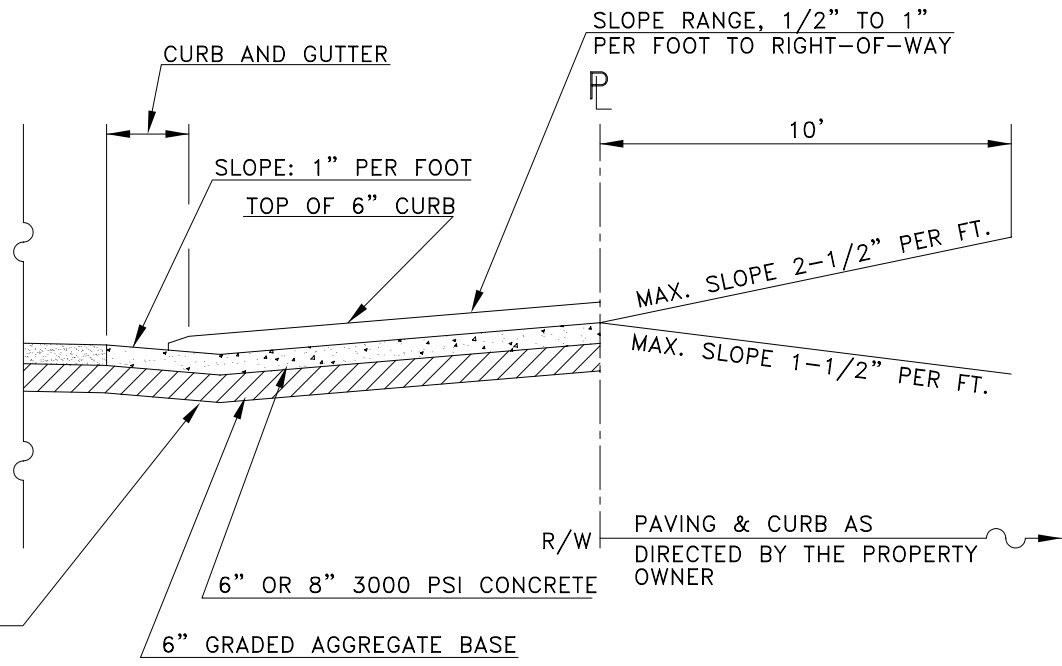

NOTE: #4 6X6 WIRE REQUIRED ON INDUSTRIAL DRIVES IF 8", = NO WIRE

**SECTION A-A**



GWINNETT COUNTY  
DEPARTMENT OF PLANNING & DEVELOPMENT  
STANDARD DRAWING

Commercial and Industrial Driveways

DATE: JANUARY 1988

SHEET: 313