

**SECTION A-A**  
 ROLLED TYPE CURB AND GUTTER  
 (WAIVER REQUIRED)

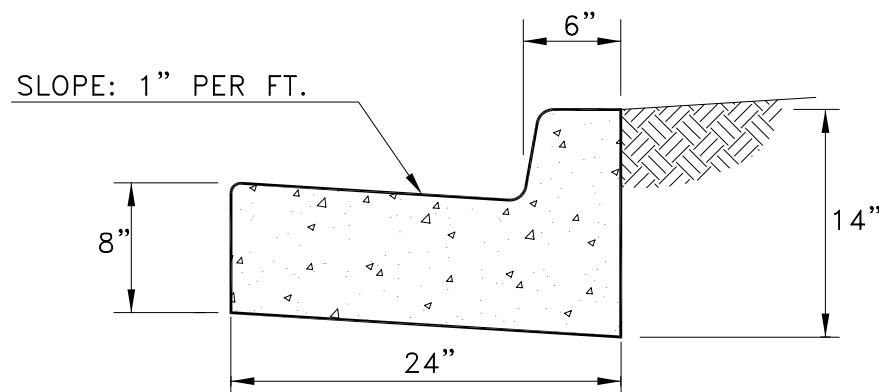

**SECTION B-B**  
 24" VERTICAL CURB AND GUTTER  
 (COMMERCIAL AND INDUSTRIAL)

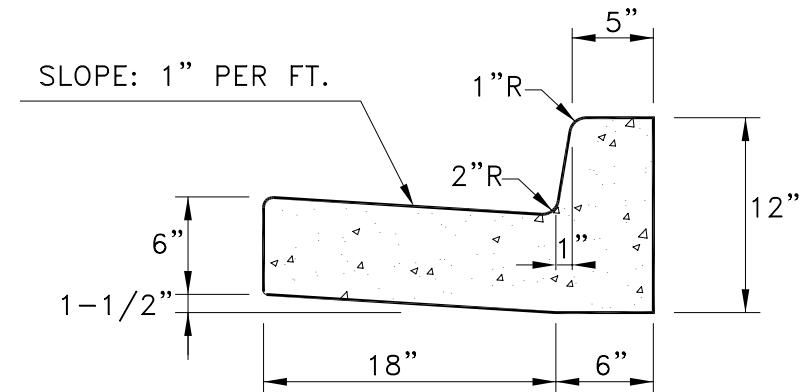

**SECTION B-B**  
 24" VERTICAL CURB AND GUTTER  
 (RESIDENTIAL)

**NOTES:**

1. EXPANSION JOINTS REQUIRED AT ALL STRUCTURES AND CURB RETURNS.
2. MAXIMUM DISTANCE BETWEEN EXPANSION JOINTS = 250'
3. CONCRETE SHALL BE CLASS A 3000 PSI.

