



June 11, 2025

**INVITATION TO BID
BL089-25**

The Gwinnett County Board of Commissioners is soliciting competitive sealed bids from qualified suppliers for the **Restoration of Landscape and Concrete Resulting from Utility Repairs on an Annual Contract** for the Department of Water Resources.

Sealed Bids will be received until 2:50 P.M. local time on July 10, 2025, at the Gwinnett County Financial Services - Purchasing Division – 4th Floor Charlotte J. Nash Building, 75 Langley Drive, Lawrenceville, Georgia 30046. Then publicly opened and read aloud at 3:00 P.M. **NOTE THAT THE PURCHASING DIVISION WILL BE TEMPORARILY RELOCATING. ALL BIDS MUST BE SUBMITTED AT THIS LOCATION.** Any bid received after this date and time will not be accepted. The bid envelope must be marked on the outside with Bid Number, name of Bidder, date and time of opening. Apparent bid results will be available the following business day on our website www.gwinnettcountry.com. Contractors providing the utility work must have a current valid Utility Contractors License.

A Webex Pre-bid Meeting is scheduled for **10:00 A.M. on June 26, 2025**. To access, dial 1-408-418-9388, enter Access code 2333 990 0518. All interested parties are urged to attend. The pre-bid conference is to be utilized by contractors and subcontractors to ask any questions in order to submit a bid for this solicitation.

Questions regarding bids should be directed to Brittany Bryant, Purchasing Associate III, at Brittany.Bryant@GwinnettCounty.com **no later than 3:00.P.M. on July 03, 2025**. Bids are legal and binding upon the vendor when submitted. All bids should be submitted in duplicate.

All suppliers must submit with bid, a bid bond, certified check or cashier's check in the amount of five percent (5%) of the total bid. **Failure to submit a bid bond with the proper rating will result in the bid being deemed non-responsive.** Successful supplier will be required to meet insurance requirements, submit a one hundred percent (100%) performance bond and a one hundred percent (100%) payment bond. Insurance and Bonding Company should be licensed to do business by the Georgia Secretary of State, authorized to do business in Georgia by The Georgia Insurance Department, listed in the Department of Treasury's Publication of Companies holding Certificates of Authority as Acceptable Surety on Federal Bonds and as acceptable reinsuring companies. **The bid bond, payment bond, and performance bond must have an A.M. Best rating of A-8 or higher.**

Gwinnett County does not discriminate on the basis of disability in the admission or access to its programs or activities. Any requests for reasonable accommodations required by individuals to fully participate in any open meeting, program or activity of Gwinnett County Government should be directed to the ADA Coordinator at the Gwinnett County Justice and Administration Center, 770-822-8165.

The written bid documents supersede any verbal or written prior communications between the parties.

Award will be made to the supplier submitting the lowest responsive and responsible bid. Gwinnett County reserves the right to reject any or all bids to waive technicalities and to make an award deemed in its best interest. Bids may be split or awarded in entirety. Gwinnett County reserves the option to negotiate terms, conditions and pricing with the lowest responsive, responsible vendor(s) at its discretion.

Award notification will be posted after award on the County website, www.gwinnettcountry.com and companies submitting a bid will be notified via email.

We look forward to your bid and appreciate your interest in Gwinnett County.

Brittany Bryant, CPPB
Purchasing Associate III

I. SCOPE OF WORK

This contract is for the restoration of public and/or private property that has been damaged, harmed, changed, touched, or otherwise affected in some way by the activities of the Gwinnett County Department of Water Resources. These activities include but are not limited to planned, unplanned, and/or emergency repairs and maintenance projects in, on, and around County easements, roads, and right-of-way, County property and facilities, State and Municipal rights-of-way, and privately owned residential and commercial properties.

Restoration of these sites may include but are not limited to, minor to moderate asphalt reconstruction of roadways, concrete flat work, construction/reconstruction of minor drainage structures, sidewalks, curb and gutter, driveways, grading, landscaping, irrigation repair, masonry structures, fence, removal and disposal of unsuitable material and other inert debris.

Time is of the utmost importance in this contract. The successful bidder will be required to coordinate his work with the designated County Officials and must carry on with the utmost diligence in order to begin and complete the work within the time frame required by the priority of the assigned work order.

II. QUALIFICATIONS

Bids will be considered only from experienced and well-equipped Contractors engaged in work of this type and magnitude. Bidders may be required to submit evidence setting forth qualifications that entitle him to consideration as a responsible Contractor. Before accepting any bid, the County may require evidence of the Contractor's financial ability to successfully perform the work to be accomplished under the contract.

Gwinnett County reserves the right to reject any or all bids, to waive informalities and re-advertise. It is understood that all bids are made subject to this agreement, that Gwinnett County reserves the right to decide which bid it deems lowest and best, and in arriving at this decision, full consideration will be given to the reputation of the bidder, his financial responsibility, and work of this type successfully completed.

III. GENERAL REQUIREMENTS

Bidders are advised to thoroughly understand the General Conditions and Special Provision Sections prior to submitting their bid.

- A.** The contractor shall supply all labor, equipment and materials needed to satisfy the requirements of the various activities included in this Contract. Work under this contract is intended to fully restore roadways, roadway items, minor concrete structures, driveways, grassed shoulders, private yards, and landscape areas to like new condition following a Gwinnett County Department of Water Resources repair or maintenance activity.
- B.** **All work shall be done in accordance with the Georgia Department of Transportation, State of Georgia Standard Specifications Construction of Transportation Systems** - latest Edition, and all supplements and addenda thereto or as Directed by the Engineer/Project Manager.
- C.** The contractor shall generally be allowed on Gwinnett County streets and roadways Monday through Friday from 7 A.M. to 6:00 P.M., excluding Gwinnett County Government holidays. However, it may be necessary for the County to restrict work hours on certain high volume roads to avoid conflicts with peak-hour traffic flow. Weekend, holiday, and night work will not be permitted without first obtaining permission from the County's authorized representative.
- D.** Traffic Control is to be performed by certified/qualified personnel, in accordance with Part 6 of the Manual on Uniform Traffic Control Devices (MUTCD) Current edition and the laws of the State of Georgia and Gwinnett County. The cost for Traffic Control shall be included in the price for the various bid items, separate or additional payment will not be considered.

- E. The contractor shall be responsible for contacting the utility "on-call" service at least 72 hours before beginning any excavation work on this contract.
- F. The County's current version of the GIS web browser includes all of the department's utility assets. Each of the items has been assigned a County "Facility ID" number. These facility numbers will be utilized and referenced by the selected Contractor throughout the life of the project. The GIS database also contains roads, parcels, topographical data, and surface features. It is the Contractors' responsibility to refer to this geographic data when working on assigned projects.
- G. The Contractor shall designate a single point of contact that will have the authority to schedule and complete work as assigned. An alternate shall be appointed for times when the primary contact is unavailable.
- H. The Contractor shall have at least one person, in a position of responsibility, always representing the Contractor on site that is capable of communicating in English with homeowners.
- I. The contractor will be responsible for coordinating and scheduling construction activities to ensure all work is performed in the most efficient way. No additional compensation will be given for rework related to damages on previous work caused by the contractor.
- J. The Contractor shall furnish, install, maintain, and remove all necessary traffic signs, barricades, lights, signals, cones and other traffic control devices and shall provide all flagging and other means of traffic protection and guidance as required by the GDOT Standard Specifications. Such work shall be considered incidental to the overall Contract and no additional compensation shall be made for it.

IV. Work Order Scheduling and Service Level Agreements

- A. Priority 1: Emergency Work Orders – Contractor is to mobilize and begin work within 24 Hours of notification. Will be paid per unit bid item price plus an emergency mobilization fee per occasion. Work is to be continuous through to completion or the additional mobilization fee will not be considered in payment.
- B. Priority 2: Normal Work Orders – Work Shall commence within 7 days of notification and be completed within 14 days of assignment. Work shall be paid per unit bid item price with no additional premium.
- C. Gwinnett County reserves the right to prioritize any work issued to contractor.
- D. Gwinnett County reserves the right to perform any work using in-house forces where deemed advantageous.

V. Material/Equipment Availability

- A. The Contractor shall maintain sufficient supply of equipment and materials on-hand to perform the essential tasks of this contract. These items include but are not limited to: all necessary hand tools, loader/backhoe, any other necessary heavy equipment, plate tamps/vibratory compactor, trucks, cones, signs, concrete forms, turf roller, and anything else of similar and/or frequent need. The contractor shall also maintain a reliable means by which to acquire additional needed material that meets the required specifications such as asphalt, concrete, topsoil, sod, seed, trees and plantings, and irrigation materials.
- B. Lead time for ordering material will be taken into consideration when assigning priority to work orders. The Contractor shall notify the County when these lead times are expected to have an impact on the schedule.

VI. SPECIAL PROVISIONS**A. Concrete:** GDOT Specifications – Sections 441-500

1. All concrete used to construct the various items shall have a minimum compressive strength of 3000 psi at 28 days.
2. The unit prices bid for "concrete curb and gutter", and "concrete driveway/sidewalk pavement", includes the removal and off site disposal of all removed and/or excavated materials at the time of excavation. Piling the debris on the street and the right of way is not acceptable. The removal and disposal of all other miscellaneous concrete (catch basin tops, etc.) will be considered incidental to the particular pay item being constructed.

NOTE: Gwinnett County will not be responsible for providing a disposal site.

3. The unit prices bid for curb, pavement, and sidewalks shall include backfilling, dressing and grassing in kind (seed with seed), regardless of who excavated the existing curb or pavement. Such work shall be incidental to the bid unit price for each item. Sod shall be replaced with same type (Bermuda, Zoysia, Fescue, etc) at the unit price stated on the bid schedule.
4. It is the contractor's responsibility to obtain positive drainage in all items and to construct all items to true lines and form with no irregularities or notify the County prior to construction if this is not deemed possible. Failure to do so will be cause for rejection and the Contractor shall remove the defective work and replace it with the acceptable work at his own expense.
5. Unless otherwise directed by the County, a front and back form shall be required on all hand poured concrete curbing.
6. Welded wire fabric (6x6 - W10xW10) shall be required in all concrete slabs and placed at mid-depth of the slab.
7. When replacing and/or constructing a concrete driveway, the existing driveway shall be cut with the concrete saw, and 1/2 inch performed joint material, full depth, used at the joint. Joint material shall also be placed between the curb and driveway if applicable.
8. "Doweled integral curb", "Header curb" and Median curb shall include #4 bar placed longitudinally along the entire length of the curb at approximately mid depth, in addition to the other requirements of GA DOT Specifications 9032 B. Cost of reinforcing materials and their installation shall be incidental to the pay items.
9. Paved Ditches- 4" Reinforced: The Contractor shall construct the paved concrete ditch with a minimum of 4" thickness of 3000 psi concrete. Concrete ditch shall be reinforced with a minimum 6" x 6" wwf w/expansion joints spaced at 30' max and construction joints at 10' max. A drop end section shall be constructed on both ends of ditch to a depth of 2'. Ditch shall be constructed to a minimum 12" depth with 2:1 side slopes or as directed by Construction Plans or Engineer/Project Manager.

B. Asphalt: GDOT Specifications – Sections 402-436

1. All bituminous asphalt concrete furnished and placed shall be hot mix recycled asphalt concrete, in accordance with Section 402 of the GDOT Standard Specifications. The Contractor shall have the right, upon notifying the County of his intention, to substitute bituminous asphalt concrete consisting of 100% virgin material. The substituted mix shall meet all applicable GDOT specifications for virgin mix. No additional compensation will be made to the Contractor for the use of virgin mix.

2. As a general operating procedure the County or its utility contractors will leave road cuts filled with graded aggregate base (GAB) up to the approximate level of adjacent undisturbed pavement. The road cuts may be covered by steel plates, depending on location of the road cut and traffic conditions.
3. The Contractor shall remove and set road plates off to the side, excavate excess GAB, square the cut up, and compact the base before patching. Where contaminated or unsuitable material is encountered in the area to be patched, the Contractor will notify the County's authorized representative for authorization to undercut below the unsatisfactory material. If authorized, the Contractor shall then undercut the unsuitable material a minimum of 4-inches and replace the undercut material with compacted GAB material meeting GDOT Standard Specifications.
4. The Contractor shall be responsible for removing debris, including the off-site disposal of all materials removed or excavated. Piling of soil or debris on the street or the right-of-way will not be acceptable. The removal and disposal of miscellaneous materials and debris will be considered incidental to the particular pay item for the work being done.
5. Where existing pavement must be removed to square the patch or to extend the patch back to solid, undisturbed pavement, the Contractor shall use a pavement saw, jack hammer, or other pavement removal device that will result in uniform, straight cuts perpendicular to the existing pavement.
6. The Contractor shall apply a compacted layer of 9.5mm or 12.5 SP.A Hot Mix Asphaltic Concrete, compacted using a vibratory roller, steel-wheeled roller, or rubber-tired roller. Vibratory plates may be used in lieu of such equipment only if approved in advance by the County's authorized representative. Hand tamping or use of the back of a shovel for compacting the asphaltic concrete will not be acceptable.
7. The surface of the finished patch must be at the same nominal height or slightly higher than the existing pavement and shall match the grade in all directions of the original pavement. Patches left lower than the existing pavement will be required to be removed and redone. Patches left higher than existing pavement such that a pronounced bump is produced when driven over in a car or light pickup shall also be removed and redone.

C. Grading and Landscape: GDOT Specifications – Section 200, Section 700

1. Sod shall be replaced with same type (Bermuda, Zoysia, Fescue, etc) at the unit price stated on the bid schedule.
2. The existing ground shall be graded and leveled to an elevation which will allow the placement of the sod and allow the final elevation of the sod to drain. All irregularities or depression in the surface due to weathering or other causes shall be filled or smoothed out before the sod is placed. If the existing surface has become hardened or crusted, it shall be disked or roto-tilled to break up to provide a bond with the sod applied. The area will be squared and shall be worked until relatively free from debris and stones.
3. Sod is to be installed with smooth, tight joints. The sod shall be placed on the prepared surface with the edges in close contact and alternate courses staggered. The sod shall be tamped or rolled and the edges or ends of any voids shall be top dressed with approved soil or sand. The entire sodded area shall be rolled so that it is of uniform appearance, true to established grade and of even surface without depressions or mounds with a professional appearance.

4. Watering and continued maintenance of newly sodded areas shall be the responsibility of the homeowner.
5. If sod is not seasonally available, grade and level the area and install mulch until the sod becomes obtainable.

D. Additional Work

1. Description: Any additional work performed by the Contractor that is not included under one of the bid unit prices in this contract will be paid for as an "extra" providing the work has been authorized in writing by the Engineer/Project Manager.
 - a) Labor - Shall be paid for at the bid unit prices for extra work, according to each worker's position, and will be paid to the nearest 1/4 hour. Unless overtime work is specifically requested and agreed to in writing by the Engineer/Project Manager in advance, all extra labor work will be paid at the bid Regular Hour Rate. The bid costs shall include all items of labor, including, but not limited to: public liability and workman's compensation insurance, social security, and old age and unemployment insurance.
 - b) Materials - Any extra materials not covered under a bid unit price elsewhere in the contract will be paid at the actual cost of the materials, as verified by the Contractor's receipt of purchase, plus percentage mark-up indicated in the bid (percentage not to exceed 10%), for overhead and profit. Materials, which are covered under a bid unit cost in the contract, will be paid for at those bid prices.

The Contractor shall give the Engineer/Project Manager access to all accounts, bills, payrolls, and vouchers relating to any extra work. In addition, no claim for compensation for such extra work will be paid unless a written invoice, fully itemized as to labor, materials, equipment, and other allowable costs, is presented to the Engineer/Project Manager within 45 days of the time the extra work was performed.

VII. MEASUREMENT AND PAYMENT

- A. **Item 1-3: Concrete Curb & Gutter**: Work performed under this line item includes providing all labor, materials, tools, traffic control and equipment necessary for the removal and installation of curb and gutter at the bid unit price per linear feet. This shall include any saw cutting necessary for clean transitions/squaring up cuts.
- B. **Item 4-5: Concrete Doweled Integral Curb & Header Curb- GA DOT 9032B**: Work performed under this line item includes providing all labor, materials, tools, traffic control and equipment necessary for the removal and installation of Concrete Integral/Header curb at the bid unit price per linear foot. This shall include any saw cutting necessary for clean transitions/squaring up cuts.
- C. **Item 6-7: Concrete Pavement for Driveways**: Work performed under this line item includes providing all labor, materials, tools, traffic control and equipment necessary for the removal and replacement of existing concrete pavement and base aggregate at the unit price per square yard. This shall include any saw cutting necessary for clean transitions/squaring up cuts.
- D. **Item 8-12: Construction of Heavy Duty Catch Basin Tops, Throats, Lids**: Work performed under this line item includes providing all labor, materials, tools, traffic control and equipment necessary for the removal and installation of heavy duty catch basin tops, throats and lids, (single wing/double wing), at the bid unit price per each. This shall include any saw cutting necessary for clean transitions/squaring up cuts.

- E. **Item 13-14: Concrete Spillway/Ditches-GA DOT 9013:** Work performed under this line item includes providing all labor, materials, tools, traffic control and equipment necessary for the removal/installation of concrete spillway/ditches **GA DOT 9013**, at the unit price per square yard. This shall include any saw cutting necessary for clean transitions/squaring up cuts.
- F. **Item 15: Concrete Sidewalk:** Work performed under this line item includes providing all labor, materials, tools, traffic control and equipment necessary for the removal/installation of concrete sidewalks, (4" thick) at the unit price per square yard. This shall include any saw cutting necessary for clean transitions/squaring up cuts.
- G. **Item 16: Handicap Ramp:** Work performed under this line item includes providing all labor, materials, tools, traffic control and equipment necessary for the removal/installation of handicap ramp at the unit price per square yard. This shall include any saw cutting necessary for clean transitions/squaring up cuts.
- H. **Item 17: Integral Concrete Median:** Work performed under this line item includes providing all labor, materials, tools, traffic control and equipment necessary for the removal/installation of concrete median at the unit price per square yard. This shall include any saw cutting necessary for clean transitions/squaring up cuts.
- I. **Item 18: Concrete Structures:** Work performed under this line item includes providing all labor, materials, tools, traffic control and equipment necessary for the removal/installation of concrete structures, (head walls, knee walls, retaining walls), at the unit price per square yard. This shall include any saw cutting necessary for clean transitions/squaring up cuts.
- J. **Item 19: Hot Mix Asphalt Patching 9.5 MM:** Work performed under this line item includes providing all labor, materials, tools, traffic control and equipment necessary for removal/installation of hot mix asphalt patching, including hot mix asphaltic concrete, 9.5 mm SP & tack at the unit price per ton. This shall include any saw cutting necessary for clean transitions/squaring up cuts.
- K. **Item 20: Hot mix Asphalt Patching 12.5 MM:** Work performed under this line item includes providing all labor, materials, tools, traffic control and equipment necessary for removal/installation of hot mix asphalt patching, including hot mix asphaltic concrete, 12.5 mm SP & tack at the unit price per ton. This shall include any saw cutting necessary for clean transitions/squaring up cuts.
- L. **Item 21: Graded Aggregate Base:** Work performed under this line item includes providing all labor, materials, tools, traffic control and equipment necessary for the installation of graded aggregate base as well as the removal of any backfill material at the unit price per ton. This shall include any saw cutting necessary for clean transitions/squaring up cuts.
- M. **Item 22: Set Up Base:** Work performed under this line item includes providing all labor, materials, tools, traffic control and equipment necessary for the installation of set up base. Includes preparing the existing base course to the required grade, smoothness and compaction, including excavating, scarifying, grading, watering and rolling the material as well as the removal of any backfill material at the unit price per square yard. This shall include any saw cutting necessary for clean transitions/squaring up cuts.
- N. **Item 23: Prime Base:** Work performed under this line item includes providing all labor, materials, tools, traffic control and equipment necessary for the installation of prime base to treat the set base with bituminous material and to provide and place blotter material (sand) at the unit price per square yard.

- O. **Item 24: Mill Asphalt Variable Depth:** Work performed under this line item includes providing all labor, materials, tools, traffic control and equipment necessary for the removal/installation of milled asphalt, (0"-2", 2"-4" and 4" and greater) at the unit price per square yard.
- P. **Item 25: Sod Replacement:** Work performed under this line item includes providing all labor, materials, tools, traffic control and equipment necessary to install sod. This includes "all types" of sod, (bermuda, centipede, zoysia, etc...), and shall also include minor grading and hand raking at the unit price per square yard.
- Q. **Item 26: Seed & Straw:** Work performed under this line item includes providing all labor, materials, tools, traffic control and equipment necessary for the installation of grass seed and straw. This shall also include minor grading and hand raking at the unit price per square yard.
- R. **Item 27: Hydroseed:** Work performed under this line item includes providing all labor, materials, tools, traffic control and equipment necessary for the application of hydroseed/hydromulch This shall also include minor grading and hand raking at the unit price per square yard as directed by the Gwinnett County DWR Project Manager.
- S. **Item 28: Topsoil:** Work performed under this line item includes providing all labor, materials, tools, traffic control and equipment necessary for the removal/installation of topsoil at the unit price per cubic feet. This shall also include minor grading and hand raking necessary to complete the job.
- T. **Item 29-32: Miscellaneous Labor:** Work performed under this line item includes providing all labor, materials, tools, traffic control and equipment necessary to complete work assigned by the County which does not comply with the services identified under the other line items set out in this bid. Payment under this Line Item shall require the written preauthorization of the County as to the type of Work, and hourly limits to be undertaken. Performance of Work under this line item without receiving preauthorization shall not be considered for compensation.
- U. **Item 33: Emergency Mobilization Fee:** Work performed under this line item includes providing all labor, materials, tools, traffic control and equipment necessary to complete Priority 1: Emergency Work Orders. Payment under this Line Item shall require the written preauthorization of the County as to the type of Work, and hourly limits to be undertaken. Performance of Work under this line item without receiving preauthorization shall not be considered for compensation.
- V. **Item 34: Material Cost Plus:** Materials purchased by contractor.- Indicate Percentage above Cost (not to exceed 10%). Indicate percentage (%) above cost for materials purchased by contractor that would normally be supplied by the County. This may include items purchased by contractor in emergency situations or in situations where the county's supply may be diminished. Receipt(s) must be submitted along with invoice for approval of payment

VIII. HEAVY DUTY CATCH BASIN TOPS SPECIFICATIONS

- A. Minimum 3000 psi concrete to be used for tops with no additives. Minimum ten (10) day cure.
- B. Contractor shall obtain field measurements for all tops.
- C. Contractor shall retrieve and re-use 1033 rings and covers when possible.
- D. Contractor shall remove old top completely and dispose of properly.
- E. Contractor shall be responsible for all traffic control.
- F. Contractor shall landscape and repair damaged grass, shrubs, etc.

- G.** Contractor shall be entirely responsible for integrity of catch basin top until County inspector's approval (typically 48 hours after notification of completion).
- H.** Contractor shall be responsible to tie in the batch basin with the curb to produce a finished, professional look.
- I.** Catch basin tops shall be completed within 30 days of notification to begin.
- J.** Contractor shall spray paint the fronts of the catch basin steel with a light gray epoxy paint upon completion.
- K.** Vertical supports shall be field constructed or adjusted so that all will fit flush against supporting surface.
- L.** Georgia DOT standard, 1033 ring and cover shall be cast in place. Refer to GA DOT standards for further details.
- M.** Gwinnett County reserves the right to reject work based on poor quality or aesthetics.
- N.** Channel steel shall be mitered and welded with a continuous weld at all joints.
- O.** 1033 ring and cover shall be placed in slab so that it is positioned directly over manhole, minimum 12" from front of slab.

HEAVY DUTY CATCH BASIN TOP

(NOT TO SCALE)

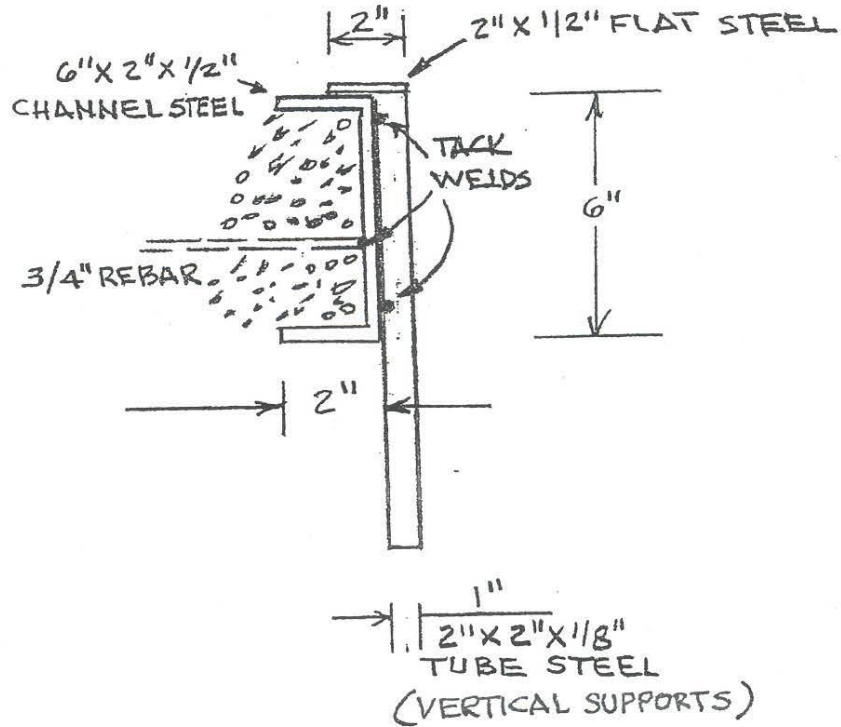
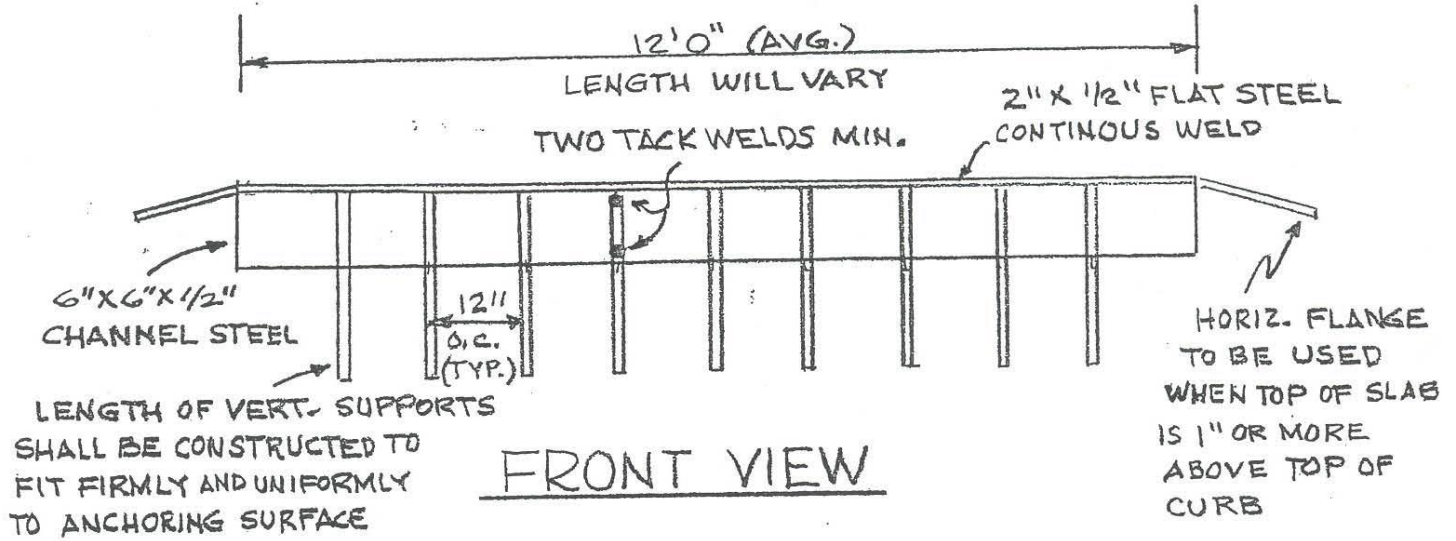

SIDE VIEW

FRONT

HEAVY DUTY CATCH BASIN TOP

(NOT TO SCALE.)

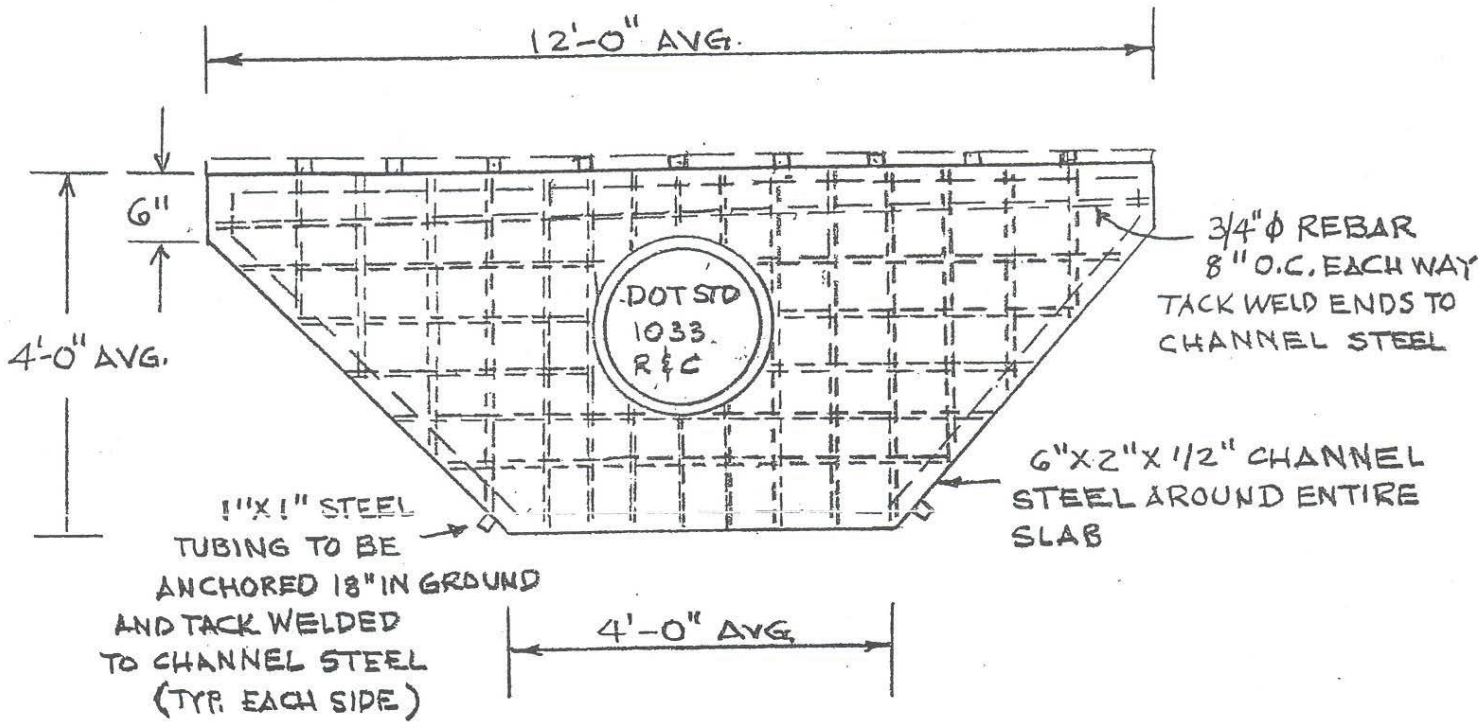

TOP VIEW

STATE	PROJECT NUMBER	SHEET NO.	TOTAL SHEETS
GA.			

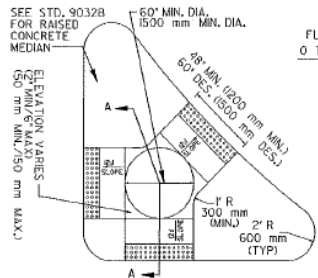
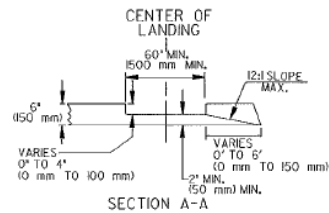

CONCRETE ISLAND WITH ELEVATED CUT THROUGH

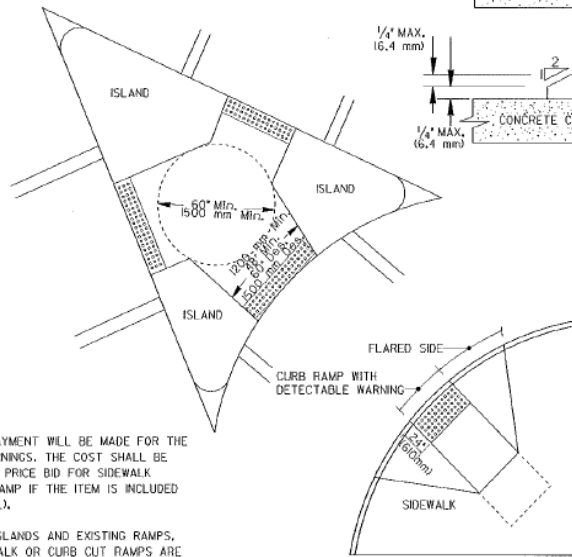

NO SEPARATE PAYMENT WILL BE MADE FOR THE DETECTABLE WARNINGS. THE COST SHALL BE INCLUDED IN THE PRICE BID FOR SIDEWALK (OR CURB CUT RAMP IF THE ITEM IS INCLUDED IN THE PROPOSAL).

FOR CUT-THRU ISLANDS AND EXISTING RAMPS, WHERE NO SIDEWALK OR CURB CUT RAMPS ARE IN THE PROPOSAL, THE COST OF THE DETECTABLE WARNINGS SHALL BE INCLUDED IN THE OVERALL BID PRICE SUBMITTED.

DETAIL FOR DETECTABLE WARNING AT CUT-THRU CONCRETE ISLAND

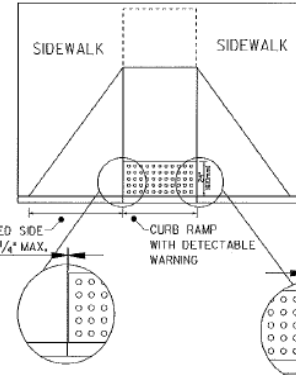

SIZE: DETECTABLE WARNINGS SHALL BE 24 INCHES (610 mm) IN THE DIRECTION OF PEDESTRIAN TRAVEL AND EXTEND THE FULL WIDTH OF THE CURB RAMP OR FLUSH SURFACE.

LOCATION: THE DETECTABLE WARNING SHALL BE LOCATED SO THAT THE EDGE NEAREST THE CURB LINE OR OTHER POTENTIAL HAZARD IS 6 TO 8 INCHES (150 mm TO 180mm) FROM THE CURB LINE OR OTHER POTENTIAL HAZARD, SUCH AS A REFLECTIVE POOL EDGE OR THE DYNAMIC ENVELOPE OF RAIL OPERATIONS.

DOME SIZE AND SPACING: TRUNCATED DOMES SHALL HAVE A BASE DIAMETER OF 0.9 INCH TO 1.4 INCH (23mm-36mm) AT THE BOTTOM, A DIAMETER OF 0.45 INCH TO 0.5 INCH (11mm-25mm) AT THE TOP, THE TOP DIAMETER SHALL BE A MINIMUM OF 50% AND A MAXIMUM OF 65% OF THE BASE DIAMETER, A HEIGHT OF 0.2 INCH (5.1mm) AND A CENTER-TO-CENTER SPACING OF 2.40 INCHES (61mm) DESIRABLE 1.60 INCHES (41mm) MINIMUM MEASURED ALONG ONE SIDE OF A SQUARE ARRANGEMENT. DOMES SHALL HAVE A SQUARE ARRANGEMENT. DOMES SHALL BE ALIGNED ON A SQUARE GRID IN THE PREDOMINANT DIRECTION OF TRAVEL TO PERMIT WHEELS TO ROLL BETWEEN DOMES.

VISUAL CONTRAST: DETECTABLE WARNING SURFACES SHALL CONTRAST VISUALLY WITH THE ADJACENT WALKING SURFACE EITHER LIGHT-ON-DARK OR DARK-ON-LIGHT. THE MATERIAL USED TO PROVIDE VISUAL CONTRAST SHALL BE AN INTEGRAL PART OF THE DETECTABLE WARNING SURFACE.

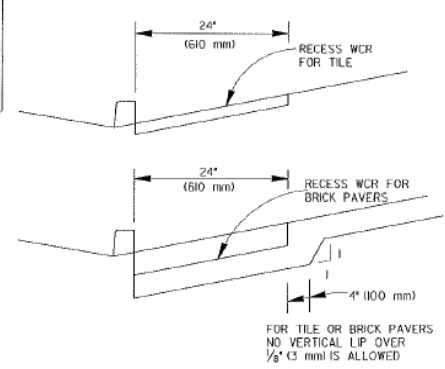
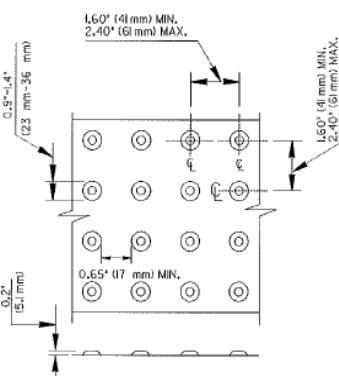
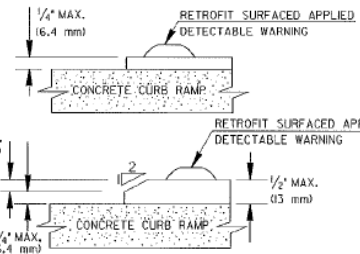
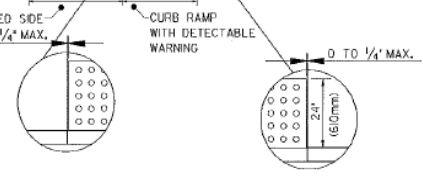

MATERIALS:

NEW CONSTRUCTION

THE DETECTABLE WARNINGS SHALL BE MADE OF MATERIALS SPECIFIED ON OPL 87.

RETROFIT OF EXISTING RAMPS

SURFACED APPLIED MATERIALS WILL ONLY BE APPROVED TO BE USED ON EXISTING WHEELCHAIR RAMPS.

INSTALLATION:

BRICK PAVERS SHALL BE SET IN A WET MORTAR BED. THE BED SHALL BE PLACED ON CONCRETE. THE CONCRETE SHALL BE A MINIMUM OF 4" THICK.

CERAMIC TILE SHALL BE EPOXIED IN PLACE OR SET IN A WET MORTAR BED. MANUFACTURER RECOMMEND ADHESIVE OR FASTENER SHALL BE USED IN THE INSTALLATION.

ALL OTHER MATERIALS SHALL BE INSTALLED ACCORDING TO MANUFACTURER'S DETAILS OR INSTRUCTION.

GENERAL NOTES:

RETROFIT SURFACED APPLIED MATERIALS ONLY:

- CHANGES IN LEVEL OF 1/4" (6.4 mm) HIGH MAXIMUM SHALL BE PERMITTED VERTICALLY ON SURFACED APPLIED MATERIALS.
- CHANGES IN LEVEL BETWEEN 1/4" (6.4 mm) HIGH MINIMUM AND 1/2" (13 mm) HIGH MAXIMUM SHALL BE BEVELED WITH A SLOPE NOT STEEPER THAN 2:1.

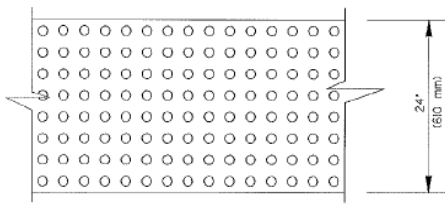

DEPARTMENT OF TRANSPORTATION STATE OF GEORGIA	
SPECIAL DETAIL	
DETECTABLE WARNING SURFACE TRUNCATED DOME SIZE, SPACING AND ALIGNMENT REQUIREMENTS	
NO SCALE	MARCH 12, 2002
BY: _____	NUMBER A4

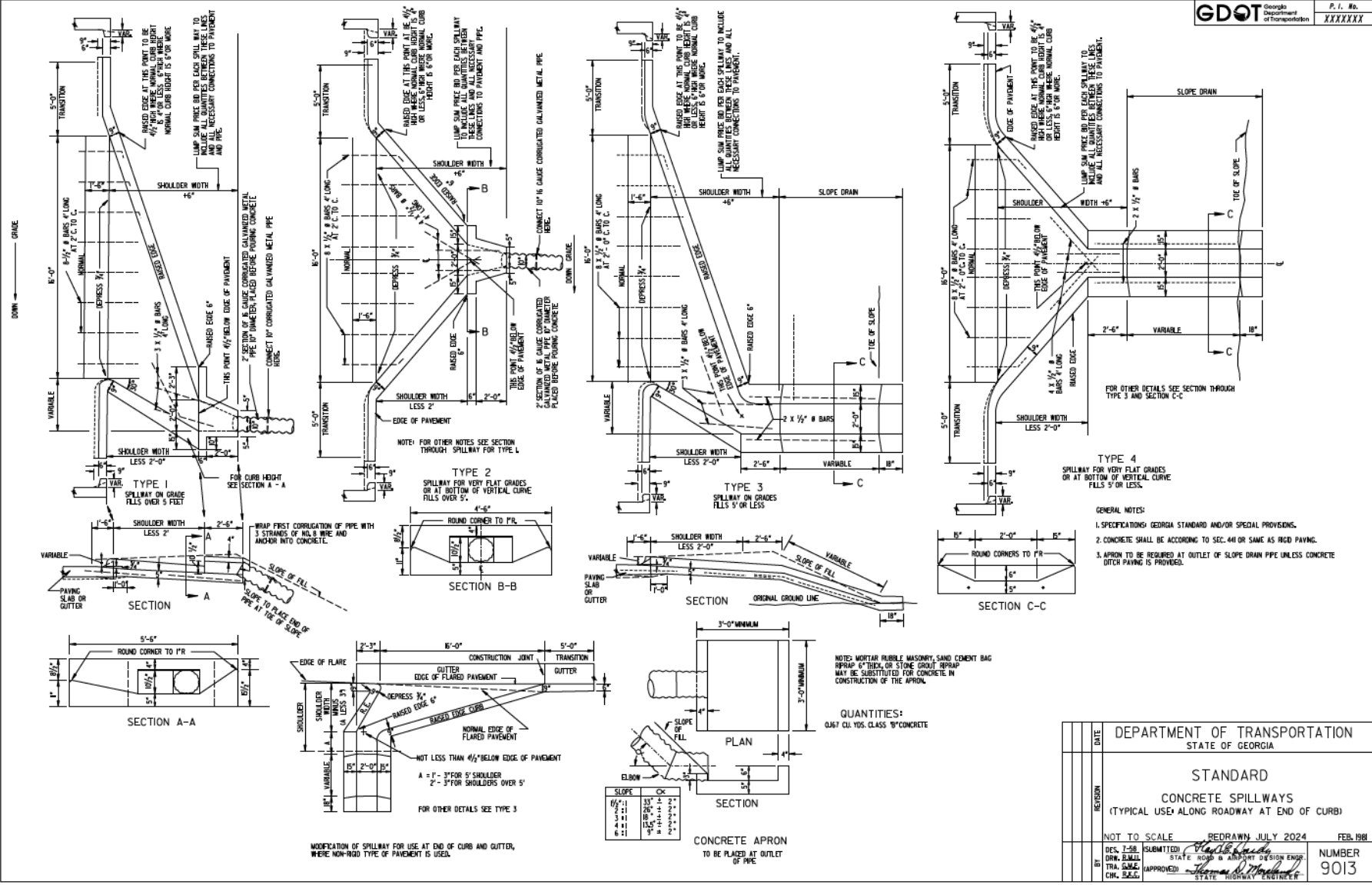

DEPARTMENT OF TRANSPORTATION		STATE OF GEORGIA	
STANDARD			
CONCRETE SPILLWAYS			
(TYPICAL USE ALONG ROADWAY AT END OF CURB)			
NOT TO SCALE		REDRAWN JULY 2024	FEB 1981
DES. 7-58	SUBMITTED	<i>Charles G. ...</i>	NUMBER 9013
DRW. 8-24	STATE ROAD & HIGHWAY DESIGN ENGR.	<i>Thomas R. ...</i>	
TRK. 5-24	CHE. ENGR.	<i>Thomas R. ...</i>	

FAILURE TO RETURN THIS PAG AS PART OF YOUR BID MAY RESULT IN REJECTION OF BID.

BID SCHEDULE

ITEM #	DESCRIPTION	APPROX. ANNUAL QTY	UNIT PRICE	TOTAL PRICE
SECTION A - CONCRETE				
1.	Concrete curb & gutter 6" x 24" x 12" high back	6,000 LF	\$	\$
2.	Concrete curb & gutter 6" x 24" x 10" roll back	200 LF	\$	\$
3.	Concrete curb & gutter 6" x 30" x 12" high back	100 LF	\$	\$
4.	Concrete doweled integral curb GA DOT 9032B including dowel bars & long reinforcement	1,000 LF	\$	\$
5.	Concrete header curb GA DOT 9032B including longitudinal reinforcement	100 LF	\$	\$
6.	6" Concrete pavement including reinforcement for driveways, parking & misc.	7,500 SY	\$	\$
7.	8" Concrete pavement including reinforcement for driveways, parking & misc.	250 SY	\$	\$
8.	Construction of heavy-duty catch basin tops, per attached specifications	10 EA	\$	\$
9.	Catch basin throats, single wing	50 EA	\$	\$
10.	Catch basin throats, double wing	50 EA	\$	\$
11.	6" Catch basin lids, single wing	50 EA	\$	\$
12.	6" Catch basin lids, double wing	50 EA	\$	\$
13.	Concrete spillway, GA DOT 9013 Type 1, 2, 3, 4, as applicable	50 SY	\$	\$
14.	Paved ditches 4" reinforced	100 SY	\$	\$
15.	Concrete sidewalk, 4" thick	6,500 SY	\$	\$
16.	Handicap Ramp with red dye squares	15 SY	\$	\$
17.	Integral concrete median 6" high; GA DOT 9032B, with dowels & type 2 face	15 SY	\$	\$
18.	Concrete structures poured in place	25 CY	\$	\$
SECTION B - ASPHALT				
19.	Hot Mix Asphalt Patching, including hot mix asphaltic concrete, 9.5 mm SP & tack	2,500 Tons	\$	\$
20.	Hot Mix Asphalt Patching, including hot mix asphaltic concrete, 12.5 mm SP & tack	1,000 Tons	\$	\$
21.	Graded Aggregate Base - in place	200 Tons	\$	\$
22.	Set Up Base	7,000 SY	\$	\$
23.	Prime Base	7,000 SY	\$	\$

COMPANY NAME _____

FAILURE TO RETURN THIS PAG AS PART OF YOUR BID MAY RESULT IN REJECTION OF BID.

BID SCHEDULE

ITEM #	DESCRIPTION	APPROX. ANNUAL QTY	UNIT PRICE	TOTAL PRICE
24.	Mill Asphalt - variable depth			
A.	0"-2"	850 SY	\$	\$
B.	2"-4"	100 SY	\$	\$
C.	4" and Greater	50 SY	\$	\$
SECTION C – GRADING AND LANDSCAPE				
25.	Sod Replacement	12,000 SY	\$	\$
26.	Seed & Straw	1,000 SY	\$	\$
27.	Hydroseed/Hydromulch	300 SY	\$	\$
28.	Topsoil in place	150 CY	\$	\$
SECTION D – MISCELLANEOUS LABOR – ADDITIONAL WORK				
29.	Foreman	10 HR	\$	\$
30.	Operator	10 HR	\$	\$
31.	Truck Driver	10 HR	\$	\$
32.	Laborer	10 HR	\$	\$
33.	Emergency Mobilization Fee- within 24 hours	1 EA	\$	\$
SECTION E – CONTINGENCY COST				
34.	Material Cost Plus Percentage (not to exceed 10%) <i>Calculate Total Price by Adding \$20,000.00 + Percent Mark-Up</i>	\$20,000.00	%	\$
OVERALL TOTAL			\$	

Gwinnett County requires pricing to remain firm for the duration of the initial term of the contract. Failure to hold firm pricing for the initial term of the contract will be sufficient cause for Gwinnett County to declare bid non-responsive. **Contract to begin October 07, 2025 or upon award.**

Unless otherwise noted, quoted prices will remain firm for four (4) additional 12-month periods. If a percentage increase/decrease is a part of the renewal options, please note this in the space provided together with an explanation.

Renewal Option 1: _____% Increase _____% Decrease Explanation_____

Renewal Option 2: _____% Increase _____% Decrease Explanation_____

Renewal Option 3: _____% Increase _____% Decrease Explanation_____

Renewal Option 4: _____% Increase _____% Decrease Explanation_____

COMPANY NAME _____

FAILURE TO RETURN THIS PAG AS PART OF YOUR BID MAY RESULT IN REJECTION OF BID.

BID SCHEDULE

Termination for Cause: The County may terminate this agreement for cause upon ten days prior written notice to the contractor of the contractor’s default in the performance of any term of this agreement. Such termination shall be without prejudice to any of the County’s rights or remedies by law.

Termination for Convenience: The County may terminate this agreement for its convenience at any time upon 30 days written notice to the contractor. In the event of the County’s termination of this agreement for convenience, the contractor will be paid for those services actually performed. Partially completed performance of the agreement will be compensated based upon a signed statement of completion to be submitted by the contractor, which shall itemize each element of performance.

Certification Of Non-Collusion In Bid Preparation _____
Signature Date

In compliance with the attached specifications and O.C.G.A. §36-91-50, the undersigned offers and agrees, if this bid is accepted by the Board of Commissioners within sixty (60) days of the date of bid opening, to furnish any or all of the items upon which prices are quoted, at the price set opposite each item, delivered to the designated point(s) within the time specified in the fee schedule. By submission of this bid, I understand that Gwinnett County uses Electronic Payments for remittance of goods and services. Vendors should select their preferred method of electronic payment upon notice of award. For more information on electronic payments, please refer to the Electronic Payment information in the instructions to vendors.

Legal Business Name _____

Address _____

Does your company currently have a location within Gwinnett County? Yes No

Representative Signature _____

Printed Name _____

Telephone Number _____ E-mail Address _____

Contact Person (if someone other than the authorized representative listed above) _____

Telephone Number _____ E-mail Address _____

FAILURE TO RETURN THIS PAGE AS PART OF YOUR BID DOCUMENT MAY RESULT IN REJECTION OF BID.

REFERENCES

Gwinnett County requests a minimum of three (3) references where work of a similar size and scope has been completed.

Note: References should be customized for each project, rather than submitting the same set of references for every project bid. The references listed should be of similar size and scope of the project being bid on. Do not submit a project list in lieu of this form.

1. Company Name _____

Brief Description of Project _____

Completion Date _____

Contract Amount \$ _____ Start Dates _____

Contact Person _____ Telephone _____

E-Mail Address _____

2. Company Name _____

Brief Description of Project _____

Completion Date _____

Contract Amount \$ _____ Start Date _____

Contact Person _____ Telephone _____

E-Mail Address _____

3. Company Name _____

Brief Description of Project _____

Completion Date _____

Contract Amount \$ _____ Start Date _____

Contact Person _____ Telephone _____

E-Mail Address _____

Company Name _____



Bid # & Description BL089-25, Restoration of Landscape and Concrete Resulting from Utility Repairs on an Annual Contract

CODE OF ETHICS AFFIDAVIT

PLEASE RETURN THIS FORM COMPLETED WITH YOUR SUBMITTAL. SUBMITTED FORMS ARE REQUIRED PRIOR TO EVALUATION.

In accordance with Section 54-33 of the Gwinnett County Code of Ordinances the undersigned bidder/proposer makes the following full and complete disclosure under oath, to the best of their knowledge, of the name(s) of all elected officials whom it employs or who have a direct or indirect pecuniary interest in or with the vendor, its affiliates or its subcontractors:

1. _____
Company Submitting Bid/Proposal

- 2. Please select one of the following:
 - No information to disclose (*complete only section 4 below*)
 - Disclosed information below (*complete section 3 & section 4 below*)

3. If additional space is required, please attach list:

Gwinnett County Elected Official Name

Gwinnett County Elected Official Name

Gwinnett County Elected Official Name

Gwinnett County Elected Official Name

4. BY: _____
Authorized Officer or Agent Signature

Sworn to and subscribed before me this
_____ day of _____, 20____

Printed Name of Authorized Officer or Agent

Notary Public

Title of Authorized Officer or Agent of Contractor

(seal)

Note: See Gwinnett County Code of Ethics Ordinance EO2011, Sec. 54-33. The ordinance will be available to view in its' entirety at **GwinnettCounty.com**



Solicitation Name & No. BL089-25, Restoration of Landscape and Concrete Resulting from Utility Repairs on an Annual Contract

**CONTRACTOR AFFIDAVIT AND AGREEMENT
(THIS FORM SHOULD BE FULLY COMPLETED AND RETURNED WITH YOUR SUBMITTAL)**

By executing this affidavit, the undersigned contractor verifies its compliance with The Illegal Immigration Reform Enhancements for 2013, stating affirmatively that the individual, firm, or corporation which is contracting with the Gwinnett County Board of Commissioners has registered with and is participating in a federal work authorization program* [any of the electronic verification of work authorization programs operated by the United States Department of Homeland Security or any equivalent federal work authorization program operated by the United States Department of Homeland Security] to verify information of newly hired employees, pursuant to the Immigration Reform and Control Act, in accordance with the applicability provisions and deadlines established therein.

The undersigned further agrees that, should it employ or contract with any subcontractor(s) in connection with the physical performance of services or the performance of labor pursuant to this contract with the Gwinnett County Board of Commissioners, contractor will secure from such subcontractor(s) similar verification of compliance with the Illegal Immigration Reform and Enforcement Act on the Subcontractor Affidavit provided in Rule 300-10-01-.08 or a substantially similar form. Contractor further agrees to maintain records of such compliance and provide a copy of each such verification to the Gwinnett County Board of Commissioners at the time the subcontractor(s) is retained to perform such service.

E-Verify * User Identification Number Date Registered

Legal Company Name

Street Address

City/State/Zip Code

BY: _____
Authorized Officer or Agent Date
(Contractor Signature)

Title of Authorized Officer or Agent of Contractor

Printed Name of Authorized Officer or Agent

SUBSCRIBED AND SWORN
BEFORE ME ON THIS THE
_____ DAY OF _____, 20_____

For Gwinnett County Use Only:
Document ID # _____
Issue Date: _____
Initials: _____

Notary Public
My Commission Expires: _____

* As of the effective date of O.C.G.A. 13-10-91, the applicable federal work authorization program is "E-Verify" operated by the U.S. Citizenship and Immigration Services Bureau of the U.S. Department of Homeland Security, in conjunction with the Social Security Administration (SSA).

Gwinnett County, Georgia

BID BOND

KNOW ALL MEN BY THESE PRESENTS: that

(Name of Contractor)

(Address of Contractor)

a _____
(Corporation, Partnership or Individual)

hereinafter called Principal, and

(Name of Surety)

(Address of Surety)

a Corporation of the State of _____, and a surety authorized by law to do business in the State of Georgia, hereinafter called Surety, are held and firmly bound unto

Gwinnett County Board of Commissioners
(Name of Oblige)

75 Langley Drive, Lawrenceville, Georgia 30046
(Address of Oblige)

Thereinafter referred to as Oblige: in the penal sum of _____ Dollars (\$ _____) in lawful money of the United States, for the payment of which sum will and truly to be made, we bind ourselves, our heirs, executors, administrators, and successors, jointly and severally, firmly by these presents.

WHEREAS, the Principal is about to submit, or has submitted, to Gwinnett County, Georgia, a proposal for furnishing materials, labor, and equipment for:

WHEREAS, the Principal desires to file this Bond in accordance with law in lieu of a certified Bidder's check otherwise required to accompany this Proposal.

NOW, THEREFORE, the conditions of this obligation are such that if the proposal be accepted, the Principal shall within ten days after receipt of notification of the acceptance, execute a Contract in accordance with the Proposal and upon the terms, conditions, and prices set forth in the form and manner required by Gwinnett County, Georgia, and execute a sufficient and satisfactory Performance Bond and Payment Bond payable to Gwinnett County, Georgia, each in the amount of 100% of the total Contract Price, in form and with security satisfactory to said Gwinnett County, Georgia, and otherwise, to be and remain in full force and virtue in law, and the Surety shall, upon failure of the Principal to comply with any or all of the foregoing requirements within the time specified above, immediately pay to Gwinnett County, Georgia, upon demand, the amount hereof in good and lawful money of the United States of America, not as a penalty, but as liquidated damages.

Gwinnett County, Georgia

PROVIDED, FURTHER, that Principal and Surety agree and represent that this bond is executed pursuant to and in accordance with the applicable provisions of the Official Code of Georgia Annotated, as Amended, including, but not limited to, O.C.G.A. § 36-91-1 et seq., and is intended to be and shall be constructed as a bond in compliance with the requirements thereof.

Signed, sealed and dated this _____ day of _____, A.D., 20_____.

ATTEST:

(Principal)

(Principal Secretary)

By: _____

(SEAL)

(Address)

(Witness as to Principal)

(Address)

(Surety)

ATTEST:

By: _____
(Attorney-in-Fact)

Resident or Nonresident Agent

(Address)

(SEAL)

(Witness as to Surety)

(Address)

NOTE: If Contractor is Partnership, all partners should execute Bond. Surety Companies executing Bonds must appear on the Treasury Department's most current list (Circular 570 as amended) and be authorized to transact business in the State where the Project is located.

Principal Secretary, Principal and Witness as to Principal signature lines must be signed by three different individuals. Additionally, Resident or Nonresident Agent, Witness as to Surety, and Attorney-in-fact must be signed by three different individuals.



Insurance:

The contractor shall provide evidence of insurance for at least the coverage and amounts set forth below. All insurance shall be maintained in the form and with a company (or companies) satisfactory to the Gwinnett County Board of Commissioners. The Contractor and their Subcontractor's/Vendor's Certificate of Insurance shall require that the County be notified in writing thirty (30) days prior to cancellation, modification or non-renewal of any insurance policy listed on Certificate. Upon request, Contractor shall provide the County with certified copies of all required insurance policies.

A. Minimum Coverage

Commercial General Liability (Occurrence Form):

General Aggregate (other than Prod/Comp Ops Liability)	\$2,000,000
Products/Completed Operations Aggregate	\$2,000,000
Personal & Advertising Injury Liability	\$1,000,000
Each Occurrence	\$1,000,000

- Gwinnett County Board of Commissioners to be named as Additional Insured
- Additional Insured Endorsement CG 20 10 (edition dates of 07/04, 04/13, 12/19 or a substitute endorsement providing equivalent coverage) and CG 2037 (edition dates of 07/04, 04/13, 12/19 or a substitute endorsement providing equivalent coverage) must be provided with your Certificate of Insurance.
- Primary and Non-Contributory Endorsement to be specified in writing
- Dedicated Limits per Project Site or Location (CG 25 03 or CG 25 04)
- Contractual Liability
- Broad Form Property Damage
- Severability of Interest
- Underground, explosion, and collapse coverage
- Personal Injury (deleting both contractual and employee exclusions)
- Incidental Medical Malpractice
- Hostile Fire Pollution Wording
- Include Waiver of Subrogation in favor of Gwinnett County Board of Commissioners
- If project or operations are within 50 ft of a railroad, Contractor is required to name the specific Railroad as an Additional Insured and provide a copy of the Additional Insured Endorsement CG2417 or its equivalent.
- In the event the General Liability insurance required by this Contract is written on a claims-made basis, Contractor warrants that any retroactive date under the policy shall precede the effective date of this Contract; and that either continuous coverage will be maintained or an extended discovery period will be exercised for a period of five (5) years or applicable statute of limitation period following completion of the work.

Automobile Liability to include:

Combined Single Limit – Each Accident \$1,000,000

- Comprehensive form providing coverage for bodily injury, death of any person, and property damage arising out of the ownership, maintenance, and use of all owned, non-owned, leased, hired, borrowed vehicles, and any other statutorily required automobile coverage.
- Gwinnett County Board of Commissioners to be named as Additional Insured
- Additional Insured Endorsements must be provided with the Certificate of Insurance
- Coverage to include loading and unloading
- Contractual Liability

Worker’s Compensation & Employer’s Liability Coverage to include:

Workers Compensation	Georgia Limits	State	Statutory
Employers Liability			
Bodily Injury by Accident – Each Accident	\$ 500,000		
Bodily Injury by Disease – Policy Limit	\$ 500,000		
Bodily Injury by Disease – Each Employee	\$ 500,000		

- Waiver of Subrogation in favor of Gwinnett County Board of Commissioners

Umbrella/Excess Liability Insurance with policy limits as determined by Contract Sums (Higher limits may be required depending on the extent of contract):

Contract Sums:

Contracts up to \$999,999	
Each Occurrence and Aggregate Limit	\$1,000,000
Contracts from \$1,000,000 to \$1,999,999	
Each Occurrence and Aggregate Limit	\$3,000,000
Contracts from \$2,000,000 to \$4,999,999	
Each Occurrence and Aggregate Limit	\$5,000,000

- Gwinnett County Board of Commissioners to be named as Additional Insured
- Additional Insured Endorsements must be provided with the Certificate of Insurance
- Concurrency of Effective Dates with Primary
- Blanket Contractual Liability
- Drop Down Feature
- Umbrella Policy must be as broad as the primary policy.
- Coverage excess over General Liability, Business Auto Liability, and Employers Liability
- In the event the Umbrella/Excess Liability insurance required by this Contract is written on a claims- made basis, Contractor warrants that any retroactive date under the policy shall precede the effective date of this Contract; and that either continuous coverage will be maintained or an extended discovery period will be exercised for a period of five (5) years or applicable statute of limitation period following completion of the work.

Builder's Risk Insurance or Installation Floater Insurance (with the exception for work where the County secures project Builders Risk)

On all new structures, bridges, overpasses, culverts, and railroad crossings, the Contractor shall purchase and maintain insurance in an amount sufficient to cover the full contract amount, from a company licensed, and authorized to do business by the Office of the Insurance and Safety Fire Commissioner of Georgia ("Insurance Commissioner"), with the exception of non-admitted carriers, in which case the broker placing coverage should be licensed by the Insurance Commissioner. All agents placing coverage should be licensed by the Insurance Commissioner, either as a resident or non-resident.

Property Insurance

The Contractor is fully and solely responsible for any physical loss or damage to all tools, equipment, construction office trailers and their contents, vehicles or any other personal property utilized in the performance of Contractor's work. Contractor agrees to waive its rights of recovery and cause its insurers, if any, to waive their rights of subrogation against Owner and Company for any such damage or loss, however caused.

Professional Liability (Errors and Omissions): Applies if contract is for professional services such as architects and engineers, geotechnical investigation and reporting, environmental assessment, land surveying, or construction administrative services such as material testing. Professional services also include accountants, lawyers, doctors, computer and software engineers, and any other services the County may designate. The following Professional Errors and Omissions Liability Insurance shall meet or exceed the following minimum requirements:

The Contractor shall maintain Errors and Omissions Liability covering negligent acts, errors and/or omissions, including design errors of the Contractor for damage sustained by reason of or in the course of operations under this Contract. The policy/coverages shall be amended to include the following:

- Claim/Wrongful Act: \$1,000,000 limit of insurance
- General Aggregate: \$2,000,000 limit of insurance
- Amendment of any Contractual Liability Exclusion to state: "This exclusion does not apply to any liability of others which you assume under a written contract provided such liability is caused by your negligent acts."
- In the event that any professional liability insurance required by this Contract is written on a claims- made basis, Contractor warrants that any retroactive date under the policy shall precede the effective date of this Contract; and that either continuous coverage will be maintained, or an extended discovery period will be exercised for a period of five (5) years or applicable statute of limitation period following completion of the work, unless such coverage becomes unavailable in the market on a commercially reasonable basis, in which case the Contractor shall notify the Insurance Manager. If the Director of the Department for which the Contractor is doing the work and the Insurance Manager both agree that such coverage is not commercially reasonably available (such agreement not to be unreasonably withheld), the Contractor may for the period such coverage is not commercially reasonably available, elect not to provide such coverage).

Pollution Liability Insurance: Applies if scope of work requires the handling and/or transportation of hazardous materials including, but not limited to, asbestos, lead, silica, contaminated soil, or any other hazardous material as defined by applicable law then the following Pollution Liability Insurance shall meet or exceed the following minimum requirements:

Per Incident Limit	\$1,000,000
Aggregate Limit	\$2,000,000

- Limits for Bodily Injury, Property Damage, Environmental Damage or Clean-Up Costs, including coverage for Non-Owned Disposal Sites.
- For Subcontractors whose scope of work includes transportation of hazardous materials, the insurance must also include coverage for pollution conditions arising from the transportation of hazardous materials.
- Whether written on an "Occurrence" basis or on a "Claims Made" basis, coverage shall either be renewed continuously or shall provide an extended claims reporting period of five (5) years or applicable statute of limitation period following completion of the work.
- Gwinnett County Board of Commissioners shall be Additional Insureds during the term of the subcontract agreement and through all applicable statutes of limitation and repose.
- The policy shall stipulate the insurance afforded to the Additional Insureds applies as primary insurance and that any other insurance carried by the Additional Insureds will be excess only.

Crane Insurance: Applies if any work to be performed involves the use of any owned, leased, chartered or hired crane of any type:

Occurrence Limit	\$5,000,000
------------------	-------------

- Evidence of coverage in the form of a Certificate of Insurance shall be provided to the County prior to start of work.
- Gwinnett County Board of Commissioners and their respective officers, directors and employees, and any other parties required by the County shall be Additional Insureds
- Additional Insured Endorsements must be provided with the Certificate of Insurance

Riggers Liability Insurance:

If any work to be performed involves the rigging, lifting, lowering, or moving of property or equipment, then those parties performing such work shall carry Rigger's Liability Insurance in an amount adequate to insure against the physical loss or damage to the property or equipment in its care.

Crime or Fidelity Insurance: Applies if scope of work includes the storage or transfer of any County data or sensitive data including but not limited to personally identifiable, health, or payment card data or the related hosting of database(s) or internet site(s):

Limit of Insurance	\$1,000,000
--------------------	-------------

- The Contractor shall maintain employee dishonesty and computer fraud coverage including, but not limited to, dishonest acts of Contractor, its employees, agents, subcontractors and anyone under Contractor's supervision or control.
- Contractor shall be liable for money, securities, or other property of the County.
- Such coverage shall include an owner coverage endorsement for County and County shall be included as a loss payee.

Cyber Liability Insurance:

Limit of Insurance per Claim	\$1,000,000
Aggregate Limit	\$1,000,000

The Contractor shall maintain insurance coverage for network security and privacy risks, including, but not limited to, insurance for data breach or introduction of virus or malicious codes, consumer notification, whether or not required by law, forensic investigation, public relations and crisis management and credit or identity monitoring or similar remediation services, unauthorized access, failure of security information theft, damage to destruction of or alteration of electronic information, breach of privacy perils, wrongful disclosure and release of private information, collection, or other negligence in the handling of confidential information, and including coverage for related regulatory fines, defenses, and penalties allowed by law

Aviation Insurance: Applies if scope of work requires the use of aircraft, including helicopters, unmanned aircraft systems (e.g., drones) and/or fixed-wing aircraft:

Maintain (or require aircraft owner or operator to maintain), and Contractor shall furnish proof of, Aircraft Liability insurance with minimum limits of \$10,000,000 per occurrence for bodily injury and property damage of all aircraft.

Unmanned aircraft systems, minimum limits of \$2,000,000 for bodily injury, property damage, and personal injury (including invasion of privacy) for unmanned aircraft systems, and guest voluntary settlement bodily injury coverage (for any aircraft except unmanned aircraft systems)

- Such policy shall include contractual liability covering all owned and non-owned aircraft
- If the party providing the Aircraft Liability insurance is not Contractor, then Contractor shall require such party to (a) waive any subrogation rights of recovery they and/or their insurance carriers may have against County and any other indemnified parties and (b) name County and such other parties as Additional Insureds
- The Contractor shall (or shall require aircraft owner or operator) to hire, employ, and utilize pilots certified by the Federal Aviation Administration to operate any such aircraft.

- B. Gwinnett County Board of Commissioners (and any applicable Authority) must be specified in writing as an Additional Insured on General Liability, Auto Liability, Umbrella Liability, Pollution, Aviation (if applicable) and Crane policies.
- C. Gwinnett County should be provided with a minimum of 30 days advance written notice of cancellation, material change, or non-renewal of policies required by the contract.
- D. Certificate Holder should read:
 Gwinnett County
 Board of Commissioners
 75 Langley Drive
 Lawrenceville, GA 30046-6935
- E. Insurance Company, except Worker' Compensation carrier, must have an A.M. Best Rating of A-8 or higher. Certain Workers' Comp funds may be acceptable by the approval of the Insurance Unit. European markets including those based in London and domestic surplus lines markets that operate on a non-admitted basis are exempt from this requirement provided that the contractor's broker/agent can provide financial data to establish that a market is equal to or exceeds the financial strengths associated with the A.M. Best's rating of A-8 or better.
- F. Insurance companies providing coverage should be licensed, and authorized to do business by the Office of the Insurance and Safety Fire Commissioner of Georgia ("Insurance Commissioner"), with the exception of non- admitted carriers, in which case the broker placing coverage should be licensed by

the Insurance Commissioner. All agents placing coverage should be licensed by the Insurance Commissioner, either as a resident or non- resident.

- G. Certificates of Insurance, and any subsequent renewals, must reference each corresponding bid/contract by project name and project/bid number.
- H. The Contractor shall agree to provide complete certified copies of current insurance policy(ies) or a certified letter from the insurance company(ies) if requested by the County to verify the compliance with these insurance requirements.
- I. All insurance coverage required to be provided by the Contractor will be primary over any insurance program carried by the County.
- J. Contractor shall incorporate a copy of the insurance requirements as herein provided in each and every subcontract with each and every Subcontractor in any tier and shall require each and every Subcontractor of any tier to comply with all such requirements. Contractor agrees that if for any reason Subcontractor fails to procure and maintain insurance as required, all such required Insurance shall be procured and maintained by Contractor at Contractor's expense.
- K. No Contractor or Subcontractor shall commence any work of any kind under this Contract until all insurance requirements contained in this Contract have been complied with and until evidence of such compliance satisfactory to Gwinnett County as to form and content has been filed with Gwinnett County. The ACORD Certificate of Insurance or a preapproved substitute is the required form in all cases where reference is made to a Certificate of Insurance or an approved substitute.
- L. The Contractor and its insurer(s) shall agree to waive all rights of subrogation against the County, the Board of Commissioners, its officers, officials, employees, and volunteers from losses arising from work performed by the Contractor for the County.
- M. Special Form Contractors' Equipment and Contents Insurance covering owned, used, and leased equipment, tools, supplies, and contents required to perform the services called for in the Contract. The coverage must be on a replacement cost basis. The County will be included as a Loss Payee in this coverage for County owned equipment, tools, supplies, and contents.
- N. The Contractor shall make available to the County, through its records or records of its insurer, information regarding any claim related to a County project. Any loss run information available from the Contractor or its insurer relating to a County project will be made available to the County upon its request.
- O. Compliance by the Contractor and all Subcontractors with the foregoing insurance requirements shall not relieve the Contractor and Subcontractors of liability under the Contract and any applicable law.
- P. The Contractor and all Subcontractors are to comply with the Occupational Safety and Health Act of 1970, Public Law 91-956, and any other laws that may apply to this Contract.
- Q. The Contractor shall at a minimum apply risk management practices accepted by the Contractor's industry.
- R. The Contractor shall advise the County if required limits of insurance become eroded or impaired.

Surety Bonds (if required)

All of the surety requirements will stay the same except the Surety Company must have the same rating as set forth in item E above.

GENERAL CONDITIONS
To Service Provider AGREEMENT

Article

- 1 Definitions
- 2 Contract Documents
- 3 Changes and Extra Work
- 4 Personnel and Equipment
- 5 Accuracy of Work
- 6 Findings Confidential
- 7 Termination of Agreement for Cause
- 8 Termination for Convenience of the COUNTY
- 9 SERVICE PROVIDER to Cooperate with other SERVICE PROVIDERS
- 10 Indemnification
- 11 Covenant Against Contingent Fees
- 12 Insurance
- 13 Prohibited Interests
- 14 Subcontracting
- 15 Assignability
- 16 Equal Employment Opportunity
- 17 Anti-Kickback Clause
- 18 Audits and Inspectors
- 19 Ownership, Publication, Reproduction and Use
- 20 Verbal Agreement or Conversation
- 21 Independent Service provider
- 22 Notices

1 DEFINITIONS

Wherever used in this Agreement, whether in the singular or in the plural, the following terms shall have the following meanings:

- 1.1 COUNTY-means Gwinnett County, Georgia, a political subdivision of the State of Georgia.
- 1.2 SUPPLEMENTAL AGREEMENT-means a written order to SERVICE PROVIDER signed by COUNTY and accepted by SERVICE PROVIDER, effecting an addition, deletion or revision in the Work, or an adjustment in the Agreement Price or the Contract Time, issued after execution of this Agreement.
- 1.3 CONTRACT-means the Agreement Documents specifically identified and incorporated herein by reference in Section 2, CONTRACT DOCUMENTS.
- 1.4 AGREEMENT EXECUTION-means the date on which SERVICE PROVIDER executes and enters into an Agreement with the COUNTY to perform the Work.
- 1.5 AGREEMENT PRICE-means the total monies, adjusted in accordance with any provision herein, payable to the SERVICE PROVIDER under this Agreement.
- 1.6 CONTRACT TIME-means the period of time stated in this Agreement for the completion of the Work.
- 1.7 SERVICE PROVIDER-means the party or parties contracting directly with the COUNTY to perform Work pursuant to this Agreement.
- 1.8 DEPARTMENT- means the Director or designee of requesting department(s) named in this solicitation.
- 1.9 DRAWINGS-means collectively, all the drawings, receipt of which is acknowledged by the COUNTY, listed in this Agreement, and also such supplementary drawings as the SERVICE PROVIDER may issue from time to time in order to clarify or explain such drawing or to show details which are not shown thereon.
- 1.10 SPECIFICATIONS-means the written technical provisions including all appendices thereto, both general and specific, which form a part of the Agreement Documents.
- 1.11 SUBSERVICE PROVIDER-means any person, firm, partnership, joint venture, company, corporation, or entity having a contractual agreement with SERVICE PROVIDER or with any of its subservice providers at any tier to provide a part of the Work called for by this Agreement.
- 1.12 WORK-means any and all obligations, duties and responsibilities, including furnishing equipment, engineering, design, workmanship, labor and any other services or things necessary to the successful completion of the Project, assigned to or undertaken by SERVICE PROVIDER under this Agreement.
- 1.13 LIAISON-Representative of the COUNTY who shall act as Liaison between the County and the SERVICE PROVIDER for all matters pertaining to this Agreement, including review of SERVICE PROVIDER'S plans and work.

2 CONTRACT DOCUMENTS

2.1 LIST OF DOCUMENTS

The Agreement, any required bonds, the General Conditions, the Appendices, the Detailed Scope of Work, the Specifications, the Drawings, the Exhibits, and all Agreement Supplemental Agreements shall constitute the Agreement Documents.

2.2 CONFLICT AND PRECEDENCE

2.2.1 The Agreement Documents are complementary, and what is called for by one is as binding as if called for by all. In the event there are any conflicting provisions or requirements in the component parts of this Agreement, the several Agreement Documents shall take precedence in the following order:

1. Supplemental Agreements
2. Agreement
3. General Conditions
4. Detailed Scope of Work
5. Specifications
6. Drawings

3 CHANGES AND EXTRA WORK

The COUNTY may, at any time, request changes in the work to be performed hereunder. All such changes, including any increase or decrease in the amount of the SERVICE PROVIDER'S compensation, which are mutually agreed upon by and between the COUNTY and the SERVICE PROVIDER, shall be incorporated in written Supplemental Agreements to the Agreement.

4 PERSONNEL AND EQUIPMENT

The SERVICE PROVIDER represents that it has secured or will secure, at its own expense, all personnel necessary to complete this Agreement; none of whom shall be employees of, or have any contractual relationship with, the COUNTY. Primary liaison with the COUNTY will be through its designee. All of the services required hereunder will be performed by the SERVICE PROVIDER under its supervision, and all personnel engaged in the work shall be fully qualified and shall be authorized or permitted under law to perform such services.

The SERVICE PROVIDER shall employ only persons duly registered in the appropriate category in responsible charge of supervision and design of the work; and further shall employ only qualified surveyors in responsible charge of any survey work.

The SERVICE PROVIDER shall endorse all reports, contract plans, and survey data. Such endorsements shall be made by a person duly registered in the appropriate category by the Georgia State Board of Registration, being in the full employ of the SERVICE PROVIDER and responsible for the work prescribed by this Agreement.

5 ACCURACY OF WORK

The SERVICE PROVIDER shall be responsible for the accuracy of the work and shall promptly correct errors and omissions in its plans and specifications without additional compensations.

Acceptance of the work by the COUNTY will not relieve the SERVICE PROVIDER of the responsibility for subsequent correction of any errors and the clarification of any ambiguities.

6 FINDINGS CONFIDENTIAL

The SERVICE PROVIDER agrees that its conclusions and any reports are for the confidential information of the COUNTY and that it will not disclose its conclusions in whole or in part to any persons whatsoever, other than to submit its written documentation to the COUNTY, and will only discuss the same with it or its authorized representatives. Upon completion of this Agreement term, all documents, reports, maps, data and studies prepared by the SERVICE PROVIDER pursuant thereto shall become the property of the COUNTY and be delivered to the DEPARTMENT.

Articles, papers, bulletins, reports, or other materials reporting the plans, progress, analyses, or results and findings of the work conducted under this Agreement shall not be presented publicly or published without prior approval in writing of the COUNTY.

It is further agreed that if any information concerning the PROJECT, its conduct, results, or data gathered or processed should be released by the SERVICE PROVIDER without prior approval from the COUNTY, the release of same shall constitute grounds for termination of this Agreement without indemnity to the SERVICE PROVIDER, but should any such information be released by the COUNTY or by the SERVICE PROVIDER with such prior written approval, the same shall be regarded as public information and no longer subject to the restrictions of this Agreement.

7 TERMINATION OF AGREEMENT FOR CAUSE

If through any cause the SERVICE PROVIDER shall fail to fulfill in a timely and proper manner its obligations under this Agreement, or if the SERVICE PROVIDER shall violate any of the covenants, agreements or stipulations of this Agreement, the COUNTY shall thereupon have the right to terminate this Agreement by giving written notice to the SERVICE PROVIDER of such termination, and specifying the effective date thereof, at least ten (10) days before the effective date of such termination. Failure to maintain the scheduled level of effort as proposed and prescribed, or deviation from the aforesaid scheduler without prior approval of the COUNTY shall constitute cause for termination. In such event, all finished or unfinished documents, maps, data, studies, work papers and reports prepared by the SERVICE PROVIDER under this Agreement shall become the property of the COUNTY, and the SERVICE PROVIDER shall be entitled to receive just and equitable compensation for any satisfactory work completed on such documents, as determined by the COUNTY.

8 TERMINATION FOR CONVENIENCE OF THE COUNTY

The COUNTY may terminate this Agreement for its convenience at any time upon 30 days notice in writing to the SERVICE PROVIDER. If the Agreement is terminated by the COUNTY as provided in this Article 8, the SERVICE PROVIDER will be paid compensation for those services actually performed. Partially completed tasks will be compensated for based on a signed statement of completion to be submitted by the SERVICE PROVIDER which shall itemize each task element and briefly state what work has been completed and what work remains to be done.

All such expenses shall be properly documented and submitted to the COUNTY for processing and payment. The County shall be the final authority in the event of any disputes over authorized costs between the COUNTY and the Service Provider.

9 SERVICE PROVIDERS TO COOPERATE WITH OTHER SERVICE PROVIDERS

If the COUNTY undertakes or awards other contracts for additional related work, the SERVICE PROVIDER shall fully cooperate with such other SERVICE PROVIDERS and the COUNTY employees or appointed committee(s), and carefully fit its own work to such additional work as may be directed by the COUNTY. The SERVICE PROVIDER shall not commit or permit any act which will interfere with the performance of work by any other SERVICE PROVIDER or COUNTY employees.

10 INDEMNIFICATION

SERVICE PROVIDER agrees to protect, defend, indemnify, and hold harmless the COUNTY, its commissioners, officers, agents and employees from and against any and all liability, damages, claims, suits, liens, and judgments, for whatever nature, including claims for contribution and/or indemnification, for injuries to or death of any person or persons, or damage to the property or other rights of any person or persons to the extent arising out of and attributed to the negligent acts, errors or omissions of the SERVICE PROVIDER. SERVICE PROVIDER'S obligation to protect, defend, indemnify, and hold harmless, as set forth herein above shall include any matter arising out of any patent, trademark, copyright, or service mark, or any actual or alleged unfair competition disparagement of product or service, or other business tort of any type whatsoever, or any actual or alleged violation of trade regulations.

SERVICE PROVIDER further agrees to protect, defend, indemnify, and hold harmless the COUNTY, its commissioners, officers, agents, and employees from and against any and all claims or liability for compensation under the Worker's Compensation Act arising out of injuries sustained by any employee of the SERVICE PROVIDER.

11 COVENANT AGAINST CONTINGENT FEES

The SERVICE PROVIDER warrants that no person or selling agency has been employed or retained to solicit or secure this Agreement upon an agreement or understanding for a commission, percentage, brokerage, or contingent fee, excepting bona fide employees or bona fide established commercial or selling agencies maintained by SERVICE PROVIDER for the purpose of securing business and that the SERVICE PROVIDER has not received any non-COUNTY fee related to this Agreement without the prior written consent of the COUNTY. For breach or violation of this warranty, the COUNTY shall have the right to annul this Agreement without liability or at its discretion to deduct from the Agreement Price of consideration the full amount of such commission, percentage, brokerage or contingent fee.

12 INSURANCE

The SERVICE PROVIDER shall, at all times that this Agreement is in effect, cause to be maintained in force and effect an insurance policy (s) that will ensure and indemnify both GWINNETT COUNTY and SERVICE PROVIDER against liability or financial loss resulting from injuries occurring to persons or property or occurring as a result of any negligent error, act, or omission of the SERVICE PROVIDER during the term of this Agreement. The liability under such insurance policy shall be not less than as stated in the Bid Proposal.

The SERVICE PROVIDER shall provide, at all times that this Agreement is in effect, Worker's Compensation insurance in accordance with the laws of the State of Georgia.

The SERVICE PROVIDER shall provide, at all times that this Agreement is in effect, Professional Liability Insurance with a limit of not less than that as stated in the Bid Proposal.

Additionally, SERVICE PROVIDER shall provide, at all times that this Agreement is in effect, automobile liability insurance with a limit of not less than that as stated in the Bid Proposal.

The policies shall be written by a responsible company(s), to be approved by the COUNTY, and shall be non-cancelable except on thirty-(30) days' written notice to the COUNTY. Such policies shall name the COUNTY as additional insured, except for worker's compensation and professional liability policies, and a copy of such policy or a certificate of insurance shall be filed with the Director at the time of the execution of this Agreement.

13 PROHIBITED INTERESTS

13.1 Conflict of Interest: The SERVICE PROVIDER agrees that it presently has no interest and shall acquire no interest, direct or indirect, that would conflict in any manner or degree with the performance of its services hereunder.

13.2 Interest of Public Officials: No member, officer, or employee of the COUNTY during his tenure or for one year thereafter, shall have any interest, direct or indirect, in this Agreement or the proceeds thereof.

14 SUBCONTRACTING

The SERVICE PROVIDER shall not subcontract any part of the work covered by this Agreement or permit subcontracted work to be further subcontracted without the DEPARTMENT's prior written approval of the subservice provider, except as may have been specifically stated in the SERVICE PROVIDER'S response to proposal per Exhibit A. The DEPARTMENT will not approve any subservice provider for work covered by this Agreement that has not been recommended for approval by the Department Director.

All subcontracts in the amount of \$5,000 or more shall include the provisions set forth in this Agreement.

15 ASSIGNABILITY

The SERVICE PROVIDER shall not assign or transfer whether by an assignment or novation, any of its rights, obligations, benefits, liabilities or other interest under this Agreement without the written consent of the COUNTY.

16 EQUAL EMPLOYMENT OPPORTUNITY

During the performance of this Agreement, the SERVICE PROVIDER agrees as follows: (1) the SERVICE PROVIDER will not discriminate against any employee or applicant for employment because of race, creed, color, sex or national origin; (2) the SERVICE PROVIDER will, in all solicitations or advertisements for employees placed by qualified applicants, receive consideration for employment without regard to race, creed, color, sex or national origin; (3) the SERVICE PROVIDER will cause the foregoing provisions to be inserted in all subcontracts for any work covered by the Agreement so that such provision will be binding upon each subservice provider, provided that the foregoing provision shall not apply to contracts or subcontracts for standard commercial supplies of raw materials.

17 ANTI-KICKBACK CLAUSE

Salaries of architects, draftsmen, technical engineers and engineers, and technicians performing work under this Agreement shall be paid unconditionally and not less often than once a month without deduction or rebate on any account except only such payroll deductions as are mandatory by law. The SERVICE PROVIDER hereby promises to comply with all applicable "Anti-kickback" laws, and shall insert appropriate provisions in all subcontracts covering work under this Agreement.

18 AUDITS AND INSPECTORS

At any time during normal business hours and as often as the COUNTY may deem necessary, the CONSULTANT shall make available to the COUNTY for examination all of its records with respect to all matters covered by this Agreement. It shall also permit the COUNTY to audit, examine and make copies, excerpts or transcripts from such records of personnel, conditions of employment and other data relating to all matters covered by this Agreement.

The SERVICE PROVIDER shall maintain all books, documents, papers, accounting records and other evidence pertaining to costs incurred on the Project and used in support of its proposal and shall make such material available at all reasonable times during the period of the Agreement, and for three years from the date of final payment under the Agreement, for inspection by the COUNTY or any reviewing agencies, and copies thereof shall be furnished upon request. The SERVICE PROVIDER agrees that the provisions of this Article shall be included in any Agreements it may make with any subservice provider, assignee, or transferee.

19 OWNERSHIP, PUBLICATION, REPRODUCTION AND USE

All documents and materials prepared pursuant to this Agreement are the property of the COUNTY. The COUNTY shall have the unrestricted authority to publish, disclose, distribute, and otherwise use, in whole or in part, any reports, data, maps, or other materials prepared under this Agreement without according credit of authorship. The COUNTY shall hold harmless and indemnify the SERVICE PROVIDER against all claims arising out of such use of documents and materials without the SERVICE PROVIDER'S knowledge and consent.

20 VERBAL AGREEMENT OR CONVERSATION

No verbal agreement or conversation with any officer, agent, or employee of the COUNTY, either before, during, or after the execution of this Agreement, shall affect or modify any of the terms or obligations herein contained, nor shall such verbal agreement or conversation entitle the SERVICE PROVIDER to any additional payment whatsoever under the terms for this Agreement. All changes to this Agreement shall be in writing and appended hereto as prescribed in Article 3 above.

21 INDEPENDENT SERVICE PROVIDER

The SERVICE PROVIDER shall perform the services under this Agreement as an independent service provider and nothing contained herein shall be construed to be inconsistent with this relationship or status. Nothing in this Agreement shall be interpreted or construed to constitute the SERVICE PROVIDER or any of its agents or employees to be the agent, employee, or representative of the COUNTY.

22 NOTICES

All notices shall be in writing and delivered in person or transmitted by certified mail, postage prepaid.

Gwinnett County requires that all Contracts between parties be entered into via the following documents. If any exceptions are taken to any part of this document, each must be stated in detail and submitted as part of your bid document. If no exceptions are noted, it is assumed that the party fully agrees to the contract in its entirety. Exceptions to the sample contract provided in this request for bid will be considered in terms of responsiveness when making the award.

ANNUAL SERVICE PROVIDER CONTRACT BL089-25

This **CONTRACT** made and entered into by and between Gwinnett County, Georgia (Party of the First Part, hereinafter called the "County"), and _____, (Party of the Second Part, hereinafter called the "Service Provider").

NOW THEREFORE, for and in consideration of the mutual promises and obligations contained herein and under the conditions hereinafter set forth, the parties do hereby agree as follows:

1. TERM:

This contract shall commence ____ (insert date) _____, for a one-year period with four (4) options to renew for an additional one-year period.

2. ATTACHMENTS:

This Contract shall consist of the Service Provider's bid/proposal and all Invitations to Bid/Proposals including all drawings, specifications, price lists, Instructions to Bidders, General Conditions, Special Provisions, Detailed Specifications, addenda, and change orders issued after execution of the Contract (hereinafter collectively referred to as the "Bid"), which are specifically incorporated herein by reference (Exhibit A). In the event of a conflict between the County's contract documents and the Service Provider's bid/proposal, the County's contract documents shall control.

3. PERFORMANCE:

Service Provider agrees to furnish all skill and labor of every description necessary to carry out and complete in good, firm and substantial, workmanlike manner, the work specified, in strict conformity with the Bid.

4. PRICE:

As full compensation for the performance of this Contract, the County shall pay the Service Provider for the actual quantity of work performed. Bid amount shown on Exhibit A is the total obligation of the County pursuant to OCGA section 36-60-13 (a) (3). The fees for the work to be performed under this Contract shall be charged to the County in accordance with the rate schedule referenced in the Bid (Exhibit A). The County agrees to pay the Service Provider following receipt by the County of a detailed invoice, reflecting the actual work performed by the Service Provider.

5. INDEMNIFICATION AND HOLD HARMLESS:

Service Provider agrees to protect, defend, indemnify, and hold harmless the COUNTY, its commissioners, officers, agents and employees from and against any and all liability, damages, claims, suits, liens, and judgments, for whatever nature, including claims for contribution and/or indemnification, for injuries to or death of any person or persons, or damage to the property or other rights of any person or persons to the extent arising out of and attributed to the negligent acts, errors, or omissions of the Service Provider. Service Provider's obligation to protect, defend, indemnify, and hold harmless, as set forth hereinabove shall include any matter arising out of any patent, trademark, copyright, or service mark, or any actual or alleged unfair competition disparagement of product or service, or other business tort of any type whatsoever, or any actual or alleged violation of trade regulations.

Service Provider further agrees to protect, defend, indemnify, and hold harmless the COUNTY, its commissioners, officers, agents, and employees from and against any and all claims or liability for compensation under the Worker's Compensation Act arising out of injuries sustained by any employee of the Service Provider.

6. TERMINATION FOR CAUSE:

The County may terminate this Contract for cause upon ten (10) days prior written notice to the Service Provider of the Service Provider's default in the performance of any term of this Contract. Such termination shall be without prejudice to any of the County's rights or remedies provided by law.

7. TERMINATION FOR CONVENIENCE:

The County may terminate this Contract for its convenience at any time upon 30 days written notice to the Service Provider. In the event of the County's termination of this Contract for convenience, the Service Provider will be paid for those services actually performed. Partially completed performance of the Contract will be compensated based upon a signed statement of completion to be submitted by the Service Provider who shall itemize each element of performance.

8. CONTRACT NOT TO DISCRIMINATE:

During the performance of this Contract, the Service Provider will not discriminate against any employee or applicant for employment because of race, creed, color, sex, national origin, age, or disability which does not preclude the applicant or employee from performing the essential functions of the position. The Service Provider will also, in all solicitations or advertisements for employees placed by qualified applicants, consider the same without regard to race, creed, color, sex, national origin, age, or disability which does not preclude the applicant from performing the essential functions of the job. The Service Provider will cause the foregoing provisions to be inserted in all subcontracts for any work covered by this Contract so that such provision will be binding upon each subservice provider, providing that the foregoing provisions shall not apply to contracts or subservice providers for standard commercial supplies of raw materials.

9. ASSIGNMENT:

The Service Provider shall not sublet, assign, transfer, pledge, convey, sell or otherwise dispose of the whole or any part of this Contract or his right, title, or interest therein to any person, firm, or corporation without the previous consent of the County in writing.

10. WAIVER:

A waiver by either party of any breach of any provision, term, covenant, or condition of this Contract shall not be deemed a waiver of any subsequent breach of the same or any other provision, term, covenant, or condition.

11. SEVERABILITY:

The parties agree that each of the provisions included in this Contract is separate, distinct and severable from the other and remaining provisions of this Contract, and that the invalidity of any Contract provision shall not affect the validity of any other provision or provisions of this Contract.

12. GOVERNING LAW:

The parties agree that this Contract shall be governed and construed in accordance with the laws of the State of Georgia. This Contract has been signed in Gwinnett County, Georgia.

13. MERGER CLAUSE:

The parties agree that the terms of this Contract include the entire Contract between the parties, and as such, shall exclusively bind the parties. No other representations, either oral or written, may be used to contradict the terms of this Contract.

(Signatures Next Page)

IN WITNESS WHEREOF, the parties hereto, acting through their duly authorized agents, have caused this **CONTRACT** to be signed, sealed and delivered.

GWINNETT COUNTY, GEORGIA

By: _____

ATTEST:

APPROVED AS TO FORM:

SERVICE PROVIDER:_____

BY:_____

Signature

Print Name

Title

ATTEST:

Signature

Print Name
Corporate Secretary
(Seal)

Gwinnett County, Georgia

BOND # _____

PAYMENT BOND

KNOW ALL MEN BY THESE PRESENTS: that

(Name of Contractor)

(Address of Contractor)

a _____
(Corporation, Partnership or Individual)

hereinafter called Principal, and

(Name of Surety)

(Address of Surety)

a Corporation of the State of _____, and a surety authorized by law to do business in the State of Georgia, hereinafter called Surety, are held and firmly bound unto

Gwinnett County Board of Commissioners
(Name of Obligee)

75 Langley Drive, Lawrenceville, Georgia 30046
(Address of Obligee)

hereinafter called Obligee;

for the use and protection of all subcontractors and all persons supplying labor, services, skill, tools, machinery, materials and/or equipment in the prosecution of the work provided for in the contract hereinafter referred to in the full and just sum of

_____ Dollars

(\$ _____) in lawful money of the United States, for the payment of which sum, will and truly to be made, the Principal and Surety bind themselves, their, and each of their heirs, executors, administrators, successors and assigns, jointly and severally, firmly by these presents.

The condition of this obligation is such, as whereas the Principal entered into a certain contract, hereto attached, with the Obligee.

NOW, THEREFORE THE CONDITION OF THIS OBLIGATION IS SUCH, that if the Principal shall well, truly, and faithfully perform said Contract according to its terms, covenants, and conditions, and shall promptly pay all persons furnishing labor, materials services, skill, tools, machinery and/or equipment for use in the performance of said Contract, then this obligation shall be void; otherwise it shall remain in full force and effect.

ALL persons who have furnished labor, materials, services, skill, tools, machinery and/or equipment for use in the performance of said Contract shall have a direct right of action on this Bond, provided payment has not been made in full within ninety (90) days after the last day on which labor was performed, materials, services, skill, tools, machinery, and equipment furnished or the subcontract completed.

PROVIDED FURTHER, that said Surety to this Bond, for value received, hereby stipulates and agrees that no change, extension of time, alterations, or additions to the terms of the Contract or to the Work to be performed thereunder shall in any way affect

its obligation on this bond, and it does hereby waive notice of any such change, extension of time, alterations, or additions to the terms of the Contract or to the work to be performed thereunder.

PROVIDED, HOWEVER, that no suit or action shall be commenced hereunder by any person furnishing labor, materials, services, skill, tools, machinery, and/or equipment having a direct contractual relationship with a subcontractor, but no contractual relationship express or implied with the Principal:

Unless such person shall have given notice to the Principal within ninety (90) days after such person did, or performed the last of the work or labor, or furnished the last of the materials, services, skill, tools, machinery and/or equipment for which claim is made, stating with substantial accuracy the amount claimed and the name of the party to whom the materials, services, skill, tools, machinery and/or equipment were furnished, or for whom the work or labor was done or performed. Such a notice shall be served by mailing the same by registered mail, postage prepaid, in an envelope addressed to the Principal, at any place where an office is regularly maintained for the transaction of business, or served in any manner in which legal process may be served in the State in which the aforesaid project is located, save that such service need not be made by a public officer, and a copy of such notice shall be delivered to the Obligee, to the person and at the address provided for in the Contract, within five (5) days of the mailing of the notice to the Principal.

PROVIDED, FURTHER, that any suit under this bond must be instituted before the expiration of one (1) year after the acceptance of the public works covered by the Contract by the proper authorities.

PROVIDED, FURTHER, that Principal and Surety agree and represent that this bond is executed pursuant to and in accordance with the applicable provisions of the Official Code of Georgia Annotated, as Amended, including, but not limited to, O.C.G.A. § 36-91-1 et seq., and is intended to be and shall be construed as a bond in compliance with the requirements thereof.

[Signatures Next Page]

ATTEST:

(Principal)

(Principal Secretary)

(SEAL)

By: _____

(Address)

(Witness as to Principal)

(Address)

(Surety)

ATTEST:

By: _____
(Attorney-in-Fact)

Resident or Nonresident Agent

(SEAL)

(Address)

(Witness as to Surety)

(Address)

BONDING AGENT CONTACT INFO

Print Name _____

Company Name _____

E-Mail _____

Phone _____

NOTE: If Contractor is Partnership, all partners should execute Bond. Surety Companies executing Bonds must appear on the Treasury Department's most current list (Circular 570 as amended) and be authorized to transact business in the State where the Project is located.

Principal Secretary, Principal and Witness as to Principal signature lines must be signed by three different individuals. Additionally, Resident or Nonresident Agent, Witness as to Surety, and Attorney-in-fact must be signed by three different individuals.

Gwinnett County, Georgia

BOND # _____

PERFORMANCE BOND

KNOW ALL MEN BY THESE PRESENTS: that

(Name of Contractor)

(Address of Contractor)

a _____
(Corporation, Partnership or Individual)

hereinafter called Principal, and

(Name of Surety)

(Address of Surety)

a Corporation of the State of _____, and a surety authorized by law to do business in the State of Georgia, hereinafter called Surety, are held and firmly bound unto

Gwinnett County Board of Commissioners
(Name of Obligee)

75 Langley Drive, Lawrenceville, Georgia 30046
(Address of Obligee)

hereinafter referred to as Obligee, are held and firmly bound unto said Obligee and all persons doing work or furnishing skill, tools, machinery, supplies, or material under or for the purpose of the Contract hereinafter referred to, in the penal sum of _____ Dollars

(\$ _____) in lawful money of the United States, for the payment of which sum will and truly to be made, we bind ourselves, our heirs, executors, administrators and successors, jointly and severally, firmly by these presents.

The condition of this obligation is such, as whereas the Principal entered into a certain contract, hereto attached, with the Obligee.

NOW, THEREFORE THE CONDITION OF THIS OBLIGATION IS SUCH, that if the Principal shall well, truly, fully and faithfully perform said contract according to its terms, covenants, conditions, and agreements of said contract during the original term of said contract and any extensions thereof that may be granted by the Obligee, with or without notice to the Surety, and during the life of any guaranty required under the contract, and shall also well and truly perform and fulfill all the undertakings, covenants, terms, conditions and agreement of any and all duly authorized modifications of said contract that may hereafter be made, then this obligation shall be void, otherwise to remain in full force and effect.

PROVIDED FURTHER, that said Surety to this Bond, for value received, hereby stipulates and agrees that no change, extension of time, alterations, or additions to the terms of the Contract or to the Work to be performed thereunder shall in any way affect its obligation on this bond, and it does hereby waive notice of any such change, extension of time, alterations, or additions to the terms of the Contract or to the work to be performed thereunder.

PROVIDED, FURTHER, that Principal and Surety agree and represent that this bond is executed pursuant to and in accordance with the applicable provisions of the Official Code of Georgia Annotated, as Amended, including, but not limited to, O.C.G.A. § 36-91-1 et seq., and is intended to be and shall be construed as a bond in compliance with the requirements thereof.

(Signatures Next Page)

ATTEST:

(Principal Secretary)

(SEAL)

(Witness as to Principal)

(Address)

ATTEST:

Resident or Nonresident Agent

(SEAL)

(Witness as to Surety)

(Address)

(Principal)

By: _____

(Address)

(Surety)

By: _____
(Attorney-in-Fact)

(Address)

BONDING AGENT CONTACT INFO

Print Name _____

Company Name _____

E-Mail _____

Phone _____

NOTE: If Contractor is Partnership, all partners should execute Bond. Surety Companies executing Bonds must appear on the Treasury Department's most current list (Circular 570 as amended) and be authorized to transact business in the State where the Project is located.

Principal Secretary, Principal and Witness as to Principal signature lines must be signed by three different individuals. Additionally, Resident or Nonresident Agent, Witness as to Surety, and Attorney-in-fact must be signed by three different individuals.

**GWINNETT COUNTY
DEPARTMENT OF FINANCIAL SERVICES – PURCHASING DIVISION
GENERAL INSTRUCTIONS FOR VENDORS, TERMS AND CONDITIONS**

*****ATTENTION*****

FAILURE TO RETURN THE FOLLOWING DOCUMENTS MAY RESULT IN SUBMITTAL BEING DEEMED NON-RESPONSIVE AND AUTOMATIC REJECTION. THE COUNTY SHALL BE THE SOLE DETERMINANT OF TECHNICALITY VS. NON-RESPONSIVE SUBMITTAL:

1. FAILURE TO USE COUNTY FEE SCHEDULE.
2. FAILURE TO RETURN OR ACKNOWLEDGE APPLICABLE COMPLIANCE/SPECIFICATION SHEETS.
3. FAILURE TO RETURN OR ACKNOWLEDGE APPLICABLE ADDENDA.
4. FAILURE TO PROVIDE INFORMATION ON ALTERNATES OR EQUIVALENTS.
5. FAILURE TO PROVIDE BID BOND, WHEN REQUIRED, WILL RESULT IN SUBMITTAL BEING DEEMED NON-RESPONSIVE AND AUTOMATIC REJECTION. BID BONDS ARE NOT REQUIRED ON ALL SOLICITATIONS. BOND REQUIREMENTS ARE CLEARLY STATED ON THE INVITATION PAGE. IF CLARIFICATION IS NEEDED, CONTACT THE PURCHASING ASSOCIATE LISTED IN THE INVITATION. **IF BONDS ARE REQUIRED, FORMS WILL BE PROVIDED IN THIS SOLICITATION DOCUMENT.**
6. FAILURE TO PROVIDE CONTRACTOR AFFIDAVIT AND AGREEMENT, WHEN REQUIRED, MAY RESULT IN SUBMITTAL BEING DEEMED NON-RESPONSIVE AND REJECTED. THE CONTRACTOR AFFIDAVIT AND AGREEMENT IS NOT REQUIRED ON ALL SOLICITATIONS. IF CLARIFICATION IS NEEDED, CONTACT THE PURCHASING ASSOCIATE LISTED IN THE INVITATION.
7. FAILURE TO PROVIDE AN ETHICS AFFIDAVIT WHEN REQUIRED, MAY RESULT IN SUBMITTAL BEING DEEMED NON-RESPONSIVE AND REJECTED. THE ETHICS AFFIDAVIT IS REQUIRED ON ALL FORMAL SOLICITATIONS OVER \$100,000.00. IF CLARIFICATION IS NEEDED, CONTACT THE PURCHASING ASSOCIATE LISTED IN THE INVITATION.

I. PREPARATION OF SUBMITTAL

- A. Each vendor shall examine the drawings, specifications, schedule, and all instructions. Failure to do so will be at the vendor's risk, as the vendor will be held accountable for their submittal.
- B. Each vendor shall furnish all information required by the solicitation form or document. Each vendor shall sign the submittal and print or type his or her name on the fee schedule. The person signing the submittal should initial erasures or other changes. An authorized agent of the vendor must sign the submittal.
- C. Fee schedule pricing should have only two decimal places unless otherwise stated. In the event of a calculation error in total price, the unit pricing prevails.
- D. Except for solicitations for the sale of real property, individuals, firms, and businesses seeking an award of a Gwinnett County contract may not initiate or continue any verbal or written communications regarding a solicitation with any County officer, elected official, employee, or other County representative other than the Purchasing Associate named in the solicitation between the date of the issuance of the solicitation and the date of the final award. The Purchasing Director will review violations. If determined that such communication has compromised the competitive process, the offer submitted by the individual, firm or business may be disqualified from consideration for award. Solicitations for the sale of real property may allow for verbal or written communications with the appropriate Gwinnett County representative.
- E. Sample contracts (if pertinent) are attached. These do NOT have to be filled out with the submittal but are contained for informational purposes only. If awarded, the successful vendor(s) will be required to execute these documents prior to County execution.
- F. Effective July 1, 2013 and in accordance with the Georgia Illegal Immigration Reform Enhancements for 2013, an original signed, notarized and fully completed Contractor Affidavit and Agreement should be included with vendor's submittal, if the solicitation is for the physical performance of services for all labor or service contract(s) that exceed \$2,499.99 (except for services performed by an individual who is licensed pursuant to Title 26, Title 43, or the State Bar of Georgia). Failure to provide the Contractor Affidavit and Agreement with your submittal may result in being deemed non-responsive and automatic rejection.

II. DELIVERY

- A. Each vendor should state time of proposed delivery of goods or services.
- B. Words such as "immediate," "as soon as possible," etc. should not be used. The known earliest date or the minimum number of calendar days required after receipt of order (delivery A.R.O.) should be stated. If calendar days are used, include Saturday, Sunday, and holidays in the number.

III. EXPLANATION TO VENDORS

Any explanation desired by a vendor regarding the meaning or interpretation of the solicitation, drawings, specifications, etc. must be requested by the question cutoff deadline stated in the solicitation for a reply to reach all vendors before the deadline of the solicitation. Any information given to a prospective vendor concerning a solicitation will be furnished to all prospective vendors as an addendum to the solicitation if such information is necessary or if the lack of such information would be prejudicial to uninformed vendors. The written solicitation documents supersede any verbal or written communications between the parties. Receipt of addenda should be acknowledged in the submittal. **It is the vendor's responsibility to ensure they have all applicable addenda prior to their submittal.** This may be accomplished by

contacting the assigned Purchasing Associate prior to the submittal or visiting the Gwinnett County website.

IV. SUBMISSION OF FORMAL OFFERS/SUBMITTALS

- A. Formal bid and proposal submittals shall be enclosed in a sealed package or envelope, addressed to the Gwinnett County Purchasing Division with the name of the vendor, the date and hour of opening and the solicitation number on the face of the package or envelope. Facsimile or emailed submittals will not be considered. Any addenda should be enclosed in the sealed envelopes as well.
- B. ADD/DEDUCT: Add or deduct amounts indicated on the outside of the envelope are allowed and will be applied to the lump sum amount. Amount shall be clearly stated and should be initialed by an authorized representative.
- C. Samples of items, when required, must be submitted within the time specified and, unless otherwise specified by the County, at no expense to the County. Unless otherwise specified, samples will be returned at the vendor's request and expense, if items are not destroyed by testing.
- D. Items offered must meet required specifications and must be of a quality that will adequately serve the use and purpose for which intended.
- E. Full identification of each item submitted, including brand name, model, catalog number, etc. must be furnished to identify exactly what the vendor is offering. Manufacturer's literature may be furnished but vendor should not submit excessive marketing material.
- F. The vendor must certify that items to be furnished are new and that the quality has not deteriorated to impair its usefulness.
- G. Unsigned submittals will not be considered except in cases where it is enclosed with other documents that have been signed. The County will determine acceptability in these cases.
- H. Gwinnett County is exempt from federal excise tax and Georgia sales tax regarding goods and services purchased directly by Gwinnett County. Vendors are responsible for federal excise tax and sales tax, including taxes for materials incorporated in county construction projects. Vendors should contact the State of Georgia Sales Tax Division for additional information. Agreements where there is a cost-plus mark-up, mark-up will not be paid on taxes.
- I. Information submitted by a vendor in the solicitation process shall be subject to disclosure after the public opening in accordance with the Georgia Open Records Act.

V. WITHDRAWAL DUE TO ERRORS

Vendors must give Gwinnett County Purchasing Division written notice within two (2) business days of completion of the opening stating that they wish to withdraw their submittal without penalty for an obvious clerical or calculation error. Submittal may be withdrawn from consideration if the price was substantially lower than the other submittals due solely to a mistake therein, provided pricing was submitted in good faith, and the mistake was a clerical mistake as opposed to a judgment mistake and was due to an unintentional arithmetic error or an unintentional omission of a quantity of work, labor or material made directly in the compilation of the submittal. The unintentional arithmetic error or omission can be clearly proven through inspection of the original work papers, documents, and materials used in preparing the

submittal sought to be withdrawn. The vendor's original work papers shall be the sole acceptable evidence of error and mistake if a vendor elects to withdraw their submittal. If a quote or bid submittal is withdrawn under the authority of this provision, the lowest remaining responsive offer shall be deemed to be low bid.

No vendor who is permitted to withdraw their submittal shall, for compensation, supply any material or labor or perform any subcontract or other work agreement for the person or firm to whom the contract is awarded or otherwise benefit, directly or indirectly, from the performance of the project for which the withdrawn bid or proposal was submitted.

Vendors who fail to request withdrawal by the required forty-eight (48) hours may automatically forfeit bid bond if a bond was required. Bid may not be withdrawn otherwise.

Withdrawal is not automatically granted and will be allowed solely at Gwinnett County's discretion.

VI. TESTING AND INSPECTION

Since tests may require several days for completion, the County reserves the right to use a portion of any supplies before the results of the tests are determined. Cost of inspections and tests of any item that fails to meet the specifications, shall be borne by the vendor.

VII. F.O.B. POINT

Unless otherwise stated in the request for invitation and any resulting contract, or unless qualified by the vendor, items shall be shipped F.O.B. Destination, Freight Prepaid and Allowed. The seller shall retain title for the risk of transportation, including the filing for loss or damages. The invoice covering the items is not payable until items are delivered and the contract of carriage has been completed. Unless the F.O.B. clause states otherwise, the seller assumes transportation and related charges either by payment or allowance.

VIII. PATENT INDEMNITY

The vendor guarantees to hold the County, its agents, officers, or employees harmless from liability of any nature or kind for use of any copyrighted or uncopyrighted composition, secret process, patented or unpatented invention, articles or appliances furnished or used in the performance of the contract, for which the vendor is not the patentee, assignee, or licensee.

IX. BID BONDS AND PAYMENT AND PERFORMANCE BONDS (IF REQUIRED, FORMS WILL BE PROVIDED IN THIS DOCUMENT)

A five percent (5%) bid bond, a one hundred percent (100%) performance bond, and a one hundred percent (100%) payment bond must be furnished to Gwinnett County for any solicitation as required in the solicitation package or document. **Failure to submit a bid bond with the proper rating will result in submittal being deemed non-responsive.** Bonding company must be authorized to do business in Georgia by the Georgia Insurance Commission, listed in the Department of the Treasury's publication of companies holding certificates of authority as acceptable surety on Federal bonds and as acceptable reinsuring companies, and have an A.M. Best rating as stated in the insurance requirement of the solicitation. **The bid bond, payment bond, and performance bond must have the proper A.M. Best rating as stated in the solicitation document.**

X. DISCOUNTS

- A. Time payment discounts may be considered in arriving at net prices and in award of solicitations. Offers of discounts for payment within ten (10) days following the end of the month are preferred.
- B. In connection with any discount offered, time will be computed from the date of delivery and acceptance at destination, or from the date correct invoice or voucher is received, whichever is the later date. Payment is deemed to be made for the purpose of earning the discount on the date of the County check.

XI. AWARD

- A. Award will be made to either the highest scoring firm (for proposals) or the lowest responsive and responsible vendor (for quotes/bids). The quality of the articles to be supplied, their conformity with the specifications, their suitability to the requirements of the County, and the delivery terms will be

taken into consideration in making the award. The County may make such investigations as it deems necessary to determine the ability of the vendor to perform, and the vendor shall furnish to the County all such information and data for this purpose as the County may request. The County reserves the right to reject any submittal if the evidence submitted by, or investigation of such vendor fails to satisfy the County that such vendor is properly qualified to carry out the obligations of the contract.

- B. The County reserves the right to reject or accept any or all offers and to waive technicalities, informalities and minor irregularities in the submittals received.
- C. The County reserves the right to make an award as deemed in its best interest, which may include awarding to a single vendor or multiple vendors; or to award the whole solicitation agreement, only part of the agreement, or none of the agreement, based on its sole discretion of its best interest.
- D. In the event of proposal scores rounded to the nearest whole number result in a tie score, the award will be based on lowest cost.
- E. If proposal negotiations with the highest ranked firm are unsuccessful, the County may then negotiate with the second ranked firm and so on until a satisfactory agreement has been reached.

XII. DELIVERY FAILURES

Failure of a vendor to deliver within the time specified or within reasonable time as interpreted by the Purchasing Director, or failure to make replacement of rejected articles/services when so requested, immediately or as directed by the Purchasing Director, shall constitute authority for the Purchasing Director to purchase in the open market articles/services of comparable grade to replace the articles/services rejected or not delivered. On all such purchases, the vendor shall reimburse the County within a reasonable time specified by the Purchasing Director for any expense incurred in excess of the contract prices, or the County shall have the right to deduct such amount from monies owed the defaulting vendor. Alternatively, the County may penalize the vendor one percent (1%) per day for a period of up to ten (10) days for each day that delivery or replacement is late. Should public necessity demand it, the County reserves the right to use or consume articles/services delivered which are substandard in quality, subject to an adjustment in price to be determined by the Purchasing Director.

XIII. COUNTY FURNISHED PROPERTY

No material, labor or facilities will be furnished by the County unless so provided in the solicitation package.

XIV. REJECTION OF SUBMITTALS

Failure to observe any of the instructions or conditions in this solicitation package may constitute grounds for rejection.

XV. CONTRACT

Each submittal is received with the understanding that the acceptance in writing by the County of the offer to furnish any or all the commodities or services described therein shall constitute a contract between the vendor and the County which shall bind the vendor on his part to furnish and deliver the articles quoted at the prices stated in accordance with the conditions of said accepted submittal. The County, on its part, may order from such vendor, except for cause beyond reasonable control, and to pay for, at the agreed prices, all articles specified and delivered.

Upon receipt of a solicitation package containing a Gwinnett County "Sample Contract" as part of the requirements, it is understood that the vendor has reviewed the documents with the understanding that Gwinnett County requires that all agreements between the parties must be entered into via this document. If any exceptions are taken to any part, each must be stated in detail and submitted as part of the vendor's

submittal. If no exceptions are stated, it is assumed that the vendor fully agrees to the provisions contained in the "Sample Contract" in its entirety.

Any Consultant as defined in O.C.G.A. §36-80-28 that is engaged to develop or draft specifications/requirements or serve in a consultative role during the procurement process for any County procurement method, by entering into such an arrangement or executing a contract, the consultant agrees to abide by the current state law and: 1) Avoid any appearance of impropriety and shall follow all policies and procedures of the County, 2) Disclose to the County any material transaction or relationship pursuant to §36-80-28, that is considered a conflict of interest, any involvement in litigation or other dispute, relationship, or financial interest not disclosed in the ethics affidavit, and 3) Acknowledge that any violation or threatened violation of the agreement may cause irreparable injury to the County, entitling the County to seek injunctive relief in addition to all other legal remedies.

When the vendor has performed in accordance with the provisions of this agreement, Gwinnett County shall pay to the vendor, within thirty (30) days of receipt of any department approved payment request and based upon work completed or service provided pursuant to the contract, the sum so requested, less the retainage stated in this agreement, if any. If Gwinnett County fails to pay the vendor within sixty (60) days of receipt of a pay request based upon work completed or service provided pursuant to the contract, the County shall pay the vendor interest at the rate of ½% per month or pro rata fraction thereof, beginning the sixty-first (61st) day following receipt of pay requests. The vendor's acceptance of progress payments or final payment shall release all claims for interest on said payment.

The parties agree that this Contract shall be governed and construed in accordance with the laws of the State of Georgia.

XVI. NON-COLLUSION

Vendor declares that the submittal is not made in connection with any other vendor's submittal for the same commodity or commodities, and that the submittal is bona fide and is in all respects fair and without collusion or fraud. An affidavit of non-collusion shall be executed by each vendor. Collusion and fraud in submittal preparation shall be reported to the State of Georgia Attorney General and the United States Justice Department.

XVII. DEFAULT

The contract may be canceled or annulled by the Purchasing Director in whole or in part by written notice of default to the vendor upon non-performance or violation of contract terms. An award may be made to the next low responsive and responsible vendor, or the next highest scoring responsive and responsible proposer, or articles specified may be purchased on the open market similar to those so terminated. In either event, the defaulting vendor (or their surety) shall be liable to the County for costs to the County in excess of the defaulted contract prices; provided, however, that the vendor shall continue the performance of this contract to the extent not terminated under the provisions of this clause. Failure of the vendor to deliver materials or services within the time stipulated on their offer, unless extended in writing by the Purchasing Director, shall constitute contract default.

XVIII. TERMINATION FOR CAUSE

The County may terminate this agreement for cause upon ten days prior written notice to the vendor of the vendor's default in the performance of any term of this agreement. Such termination shall be without prejudice to any of the County's rights or remedies by law.

XIX. TERMINATION FOR CONVENIENCE

The County may terminate this agreement for its convenience at any time upon 30 days written notice to the vendor. In the event of the County's termination of this agreement for convenience, the vendor will be paid for those services actually performed. Partially completed performance of the agreement will be compensated based upon a signed statement of completion to be submitted by the vendor, which shall itemize each element of performance.

XX. SUBSTITUTIONS

Vendors offering substitutions or who are deviating from the attached specifications shall list such deviations on a separate sheet to be submitted with their offer. The absence of such a substitution list shall indicate that the vendor has taken no exception to the specifications contained herein.

XXI. INELIGIBLE VENDORS

The County may choose not to accept the offer by an individual, firm, or business who is in default on the payment of taxes, licenses, or other monies owed to the County. Additionally, vendors or persons placed on an Ineligible Source List for reasons listed in Part 6, Section II of the Gwinnett County Purchasing Ordinance shall not be eligible to provide any commodities or services to the County during the period such person remains on the Ineligible Source List.

XXII. PENDING LITIGATION

An individual, firm, or business that has litigation pending against the County, or anyone representing a firm or business in litigation against the County, not arising out of the procurement process, will be disqualified.

XXIII. OCCUPATION TAX CERTIFICATE

Each successful vendor must have a valid Gwinnett County occupation tax certificate if the vendor maintains an office within the unincorporated area of Gwinnett County. Incorporated, out of County, and out of State vendors are required to have any and all certificates necessary to do business in any town, County or municipality in the State of Georgia, or as otherwise required by County ordinance or resolution. Vendors may be required to provide evidence of valid certificates. Out of State vendors are required to have a certificate in the Georgia jurisdiction where they receive the most revenue.

XXIV. PURCHASING POLICY AND REVIEW COMMITTEE

The Purchasing Policy & Review Committee has been established to review purchasing procedures and make recommendations for changes; resolve problems regarding the purchasing process; make recommendations for standardization of commodities, schedule buying, qualified products list, annual contracts, supplier performance (Ineligible Source List), and other problems or requirements related to purchasing. The Purchasing Policy & Review Committee has authority to place vendors on the Ineligible Source List for reasons listed in Part 6, Section II of the Gwinnett County Purchasing Ordinance, for a period not to exceed three (3) years.

XXV. AMERICANS WITH DISABILITIES ACT

All vendors for Gwinnett County are required to comply with all applicable sections of the Americans with Disabilities Act (ADA) as an equal opportunity employer. In compliance with the Americans with Disabilities Act (ADA), Gwinnett County provides reasonable accommodations to permit a qualified applicant with a disability to enjoy the privileges of employment equal to those employees without disabilities. Disabled individuals must satisfy job requirements for education background, employment experience, and must be able to perform those tasks that are essential to the job with or without reasonable accommodations. Any requests for the reasonable accommodations required by individuals to fully participate in any open meeting, program or activity of Gwinnett County should be directed to the ADA Coordinator, 75 Langley Drive, Lawrenceville, Georgia 30046, 770-822-8165.

XXVI. ALTERATIONS OF SOLICITATION AND ASSOCIATED DOCUMENTS

Alterations of County documents are strictly prohibited and will result in automatic disqualification of the vendor's solicitation response. If there are "exceptions" or comments to any of the solicitation requirements or other language, then the firm may make notes to those areas, but may not materially alter any document language.

XXVII. TAX LIABILITY

Local and state governmental entities must notify vendors of their use tax liability on public works projects. Under Georgia law, private vendors are responsible for paying a use tax equal to the sales tax rate on material and equipment purchased under a governmental exemption that is incorporated into a government construction project: excluding material and equipment provided for the installation, repair, or expansion of a public water, gas, or sewer system when the property is installed for general distribution purposes. To the

extent the tangible personal property maintains its character (for example, the installation of a kitchen stove), it remains tax-exempt. However, if the installation incorporates the tangible personal property into realty (for example, the installation of sheetrock), it becomes taxable to the private vendor. See O.C.G.A. §48-8-3(2) and O.C.G.A. §48-8-63.

XXVIII. STATE AND FEDERAL LAW REGARDING WORKER VERIFICATION

Effective July 1, 2013 State Law requires that all who enter into a contract for the physical performance of services for all labor or service contract(s) that exceed \$2,499.99 (except for services performed by an individual who is licensed pursuant to Title 26, Title 43, or the State Bar of Georgia) and that all who enter into a contract for public works as defined by O.C.G.A. §36-91-2(12) for the County, must satisfy the Illegal Immigration Reform Enhancements for 2013 in conjunction with the Federal Immigration Reform and Control Act (IRCA) of 1986, in all manner, and such are conditions of the contract.

The Purchasing Division Director with the assistance of the Internal Audit Division shall be authorized to conduct random audits of a vendor's or subcontractors' compliance with the Illegal Immigration Reform Enhancements for 2013 and the rules and regulations of the Georgia Department of Labor. The vendor and subcontractors shall retain all documents and records of its compliance for a period of five (5) years following completion of the contract or shall abide by the current time requirements at the time of the contract. This requirement shall apply to all contracts for all public works, labor or service contracts that exceed \$2,499.99 except for services performed by an individual who is licensed pursuant to Title 26, Title 43, or the State Bar of Georgia.

Whenever it appears that a vendor's or subcontractor's records are not sufficient to verify the work eligibility of any individual in the employment of such vendor or subcontractor, the Purchasing Director shall report same to the Department of Homeland Security and may result in termination of the contract if it is determined at any time during the work that the vendor or subcontractor is no longer in compliance with worker verification.

By submitting an offer to the County, vendor agrees that, in the event the vendor employs or contracts with any subcontractor(s) in connection with the covered contract, the vendor will secure from the subcontractor(s) such subcontractor(s)' indication of the employee-number category applicable to the subcontractor, as well as attestation(s) from such subcontractor(s) that they follow the Illegal Immigration Reform Enhancements for 2013 in conjunction with all federal requirements. Original signed, notarized Subcontractor Affidavits and Agreements must be maintained by the vendor awarded the contract.

A vendor's or subcontractor's failure to participate in the federal work authorization program as defined above shall be subject to termination of the contract. A vendor's failure to follow Gwinnett County's instruction to terminate a subcontractor that is not participating in the federal work authorization program may be subject to termination of the contract.

XXIX. SOLID WASTE ORDINANCE

No individual, partnership, corporation, or other entity shall engage in solid waste handling except in such a manner as to conform to and comply with the current Gwinnett County Solid Waste Ordinance and all other applicable local, state and federal legislation, rules, regulation, and orders.

XXX. GENERAL CONTRACTORS LICENSE

Effective July 1, 2008: **All General Contractors must have a current valid license from the State Licensing Board for Residential and General Contractors, unless specifically exempted from holding such license pursuant to Georgia law (O.C.G.A. §43-41-17).**

XXXI. PRODUCTS MANUFACTURED IN GEORGIA

When contracting for or purchasing supplies, materials, equipment, or agricultural products that exceeds \$100,000.00, excluding beverages for immediate consumption, Gwinnett County shall give preference as

far as may be reasonable and practicable to such supplies, materials, equipment, and agricultural products as may be manufactured or produced in this state. Such preference shall not sacrifice quality. Gwinnett County Board of Commissioners shall consider, among other factors, information submitted by the vendor which may include the vendor's estimate of the multiplier effect on gross state domestic product and the effect on public revenues of the state and the effect on public revenues of political subdivisions resulting from acceptance of an offer to sell Georgia manufactured or produced goods as opposed to out-of-state manufactured or produced goods. Any such estimates shall be in writing. **(O.C.G.A. §36-84-1).**

XXXII. INDEMNIFICATION

To the fullest extent permitted by law, the vendor shall, at his sole cost and expense, indemnify, defend, satisfy all judgments, and hold harmless the County, its commissioners, officers, agents, and employees from and against all claims, damages, actions, judgments, costs, penalties, liabilities, losses and expenses, including, but not limited to, attorney's fees arising out of or resulting from the performance of the work, provided that any such claim, damage, action, judgment, cost, penalty, liability, loss or expense (1) is attributable to bodily injury, sickness, disease, or death, or to injury to or destruction of tangible property (other than the work itself) including the loss of use resulting therefrom, and (2) is caused in whole or in part by the negligent acts, errors by any act or omission of the vendor, any subcontractor, anyone directly or indirectly employed by any of them or anyone for whose acts any of them may be liable, regardless whether such claim is caused in part by a party indemnified hereunder. Such obligation shall not be construed to negate, abridge, or otherwise reduce any of the rights or obligations of indemnity which would otherwise exist as to any party or person described in this agreement. In any and all claims against the County, its commissioners, officers, agents, and employees by any employee of the vendor, any subcontractor, anyone directly or indirectly employed by any of them, or anyone for whose acts any of them may be liable, the indemnification obligation contained herein shall not be limited in any way by any limitation on the amount or type of damages, compensation, or benefits payable by or for the vendor or any subcontractor under Worker's Compensation Acts, disability benefit acts, or other employee benefit acts.

Vendor shall also indemnify, hold harmless, insure, and defend the County for damages, losses, or expenses to the extent caused by or resulting from the negligence, recklessness, or intentionally wrongful conduct of the vendor or other persons employed or utilized by the vendor in the performance of a contract that utilizes survey services.

XXXIII. CODE OF ETHICS

Vendors shall disclose under oath the name of all elected officials whom it employs or who have a direct or indirect pecuniary interest in the business entity, its affiliates, or its subcontractors. (This shall not apply to informal purchases as defined by the Purchasing Ordinance.) The vendor shall execute a Code of Ethics affidavit. Failure to submit the affidavit during the procurement process shall render the offer non-responsive.

Any business entity holding a contract with Gwinnett County that after execution of the contract or issuance of the purchase order employs, subcontracts with, or transfers a direct or indirect pecuniary interest in the business entity to an elected official shall within five (5) days disclose such fact in writing under oath to the Clerk of the Board of Commissioners. Failure to comply, or vendors submitting false information or omitting material information shall be referred to the Purchasing Policy & Review Committee for action pursuant to the Purchasing Ordinance or to the District Attorney for possible criminal prosecution. Note: See Gwinnett County Code of Ethics Ordinance EO2011, Sec. 54-33. The ordinance is available to view in its entirety at www.gwinnettcounty.com.

XXXIV. ELECTRONIC PAYMENT

Vendors accepting procurements should select one of Gwinnett County's electronic payment options.

- A. A vendor may select ePayables payment process which allows acceptance of Gwinnett County's virtual credit card as payment for outstanding invoices. The authorized vendor representative must

send an email to: vendorelectronicpayment@gwinnettcounty.com and indicate the desire to enroll in Gwinnett County's virtual credit card payment process.

- B. A vendor may select Direct Deposit payment process and the payment will be deposited directly into an account at their designated financial institution. To securely enroll in Direct Deposit, either access your online [Vendor Login and Registration](#) on the County's web site and update the requested information on the Direct Deposit tab or mail a [Direct Deposit Authorization Agreement](#) form.

The County will send a Payment Advice notification via email for both payment types. For more information about Electronic Payments, please visit the Gwinnett County Treasury Division page or click here -> [Gwinnett County Electronic Payments](#).

DIRECTIONS TO GJAC BUILDING FROM I-85

Take I-85 to Georgia Highway 316 (Lawrenceville/Athens exit). Exit Highway 120 (Lawrenceville/Duluth exit) and turn right. At seventh traffic light, turn right onto Langley Drive. Cross Highway 29 through the traffic light and proceed through the roundabout. Visitors can either proceed to the front parking area on the left or to the parking deck behind the building. Click [here](#) for additional information about parking. **The Purchasing Division is located on the fourth floor of the Charlotte J. Nash Building. NOTE THAT THE PURCHASING DIVISION HAS TEMPORARILY RELOCATED.**

FAILURE TO RETURN THIS PAGE MAY RESULT IN REMOVAL OF YOUR COMPANY FROM COMMODITY LISTING.

BL089-25

Buyer Initials: BB

IF YOU DESIRE TO SUBMIT A "NO BID" IN RESPONSE TO THIS PACKAGE, PLEASE INDICATE BY CHECKING ONE OR MORE OF THE REASONS LISTED BELOW AND EXPLAIN.

- Do not offer this product or service; remove us from your bidder's list for this item only.
- Specifications too "tight"; geared toward one brand or manufacturer only.
- Specifications are unclear.
- Unable to meet specifications
- Unable to meet bond requirements
- Unable to meet insurance requirements
- Our schedule would not permit us to perform.
- Insufficient time to respond.
- Other

COMPANY NAME _____

AUTHORIZED REPRESENTATIVE _____

SIGNATURE